

2022 FULL LINE

ORTEGA[®]
GUITARS • EST 1994

#OrtegaGuitars



**LEFT
HANDED**
PLEASE TURN OVER





HANDCRAFTED QUALITY

INNOVATIVE, CREATIVE & DIFFERENT

Established in 1994, Ortega Guitars introduced German design to authentic and traditional methods of guitar making. Committed to innovation and quality, we strive to improve what is expected at every level of all our acoustic instruments. Options like the 12hole bridge, often found only on high-end guitars, are standard on our entry level to professional nylon string guitars. Our wide variety of body and neck sizes accommodates all ages giving everyone an opportunity to learn and play.

2022 FULL LINE CATALOG

INDEX

NYLON STRING GUITARS	4	ACOUSTIC BASSES	56
Custom Master Selection	4	Deep Series	57
Traditional Series	6	The Private Room	58
Signature Series	10	Signature Series	59
Performer Series	12	MANDOLINS & BANJOS	60
Family Series Pro	16	Mandolins	60
Family Series	18	Banjos – Falcon Series	62
Student Series	24	Banjos – Raven Series	64
Gaucho Series	26	ACOUSTIC AMPLIFICATION SERIES	66
Requinto Series	27	STOMP BOX EFFECT SERIES	68
Mini Travel Series	28	PERCUSSION SERIES	70
THE PRIVATE ROOM	30	Cajons – Performer Series	70
Spalted Suite	30	Premium Cajon Bags	71
Eclipse Suite	30	Stomp Box Cajon Bundles	71
Striped Suites	31	Cajon Pedals	71
Distressed Suites	31	Professional Cajon Bags	71
ORTEGA® UKULELES	32	Kalimbas	72
Elite Series	33	Effect Series	73
Bonfire Series	34	POS	74
Art Series	35	ACCESSORIES	75
Earth Series	36	Strings	76
Onyx Series	37	Capos	79
Element Series	37	Straps	82
Gaucho Series	38	Vegan Straps & Accessories	87
Horizon Series	38	Hangers, Stands, Holder	88
The Private Room	38	Stools	90
Bamboo Series	40	Bags & Cases	91
Timber Series	41	Digital Wireless Systems	98
Prism Series	44	Cables	100
Lizard Series	44	Picks & Slides	102
Banjolele Series	45	Tuners	104
Custom Built Series	46	Care	105
UKEBASSES	48	Humidifiers & Useful Helpers	107
Bamboo Series	48	Preamps & Pickups	109
Lizard Series	49	Cables & Power	110
Custom Built Series	49	Strap Locks & Pins	111
Keiki® UKULELES	50	Tuning Machines	111
K1 Series	51		
K2 Series	51		
K3 Series	53		
Keiki® ACCESSORIES	54		
Picks	54		
Straps	55		
Ukulele Bags	55		



www.ortegaguitars.com

GLOBAL
HEADQUARTERS
Ortega
Musik-Meinel-Str. 1
91468 Gutenstetten
Germany

US HEADQUARTERS
Meinl USA L.C.
Ortega
3427 Ambrose Avenue
Nashville, TN 37207
USA



info@ortegaguitars.com



INDEX

NYLON STRING GUITARS	4
Custom Master Selection	4
Traditional Series	6
Signature Series	10
Performer Series	12
Family Series Pro	16
Family Series	18
Student Series	24
Gacho Series	26
Requinto Series	27
Mini Travel Series	28

NYLON STRING GUITARS

CUSTOM MASTER SELECTION OPTIONS

MADE IN SPAIN

SCALES & SIZES

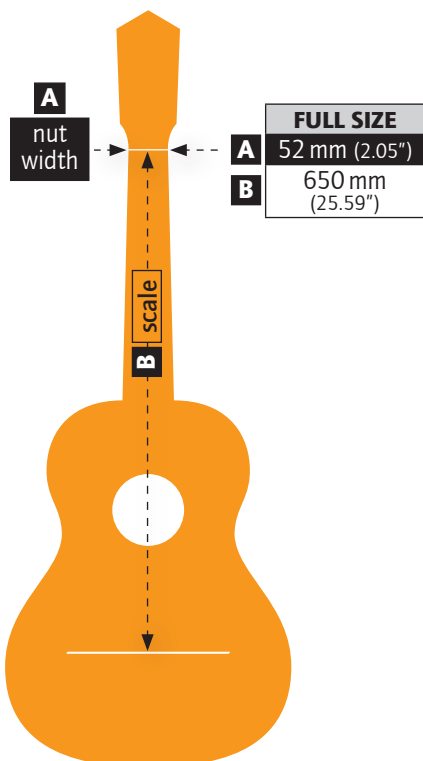

FEATURES



Spanish heel

INCL. DELUXE HARDCASE





**ALL SOLID
SPANISH HEEL**

scale: 650 mm (25.59")
nut width: 52 mm (2.05")

M5CS



- Solid European spruce top, gloss finish
- Solid mahogany back & side, gloss finish
- Rosewood binding
- Mahogany neck, gloss finish
- Rosewood fretboard & bridge
- Handmade in Spain
- Deluxe hardcase included



**ALL SOLID
SPANISH HEEL**

scale: 650 mm (25.59")
nut width: 52 mm (2.05")

M4CS



- Solid Canadian Red Western cedar top, gloss finish
- Solid European walnut back & side, gloss finish
- Rosewood binding
- Mahogany neck, gloss finish
- Rosewood fretboard & bridge
- Handmade in Spain
- Deluxe hardcase included



TRADITIONAL SERIES OPTIONS

MADE IN
SPAIN

SCALES & SIZES

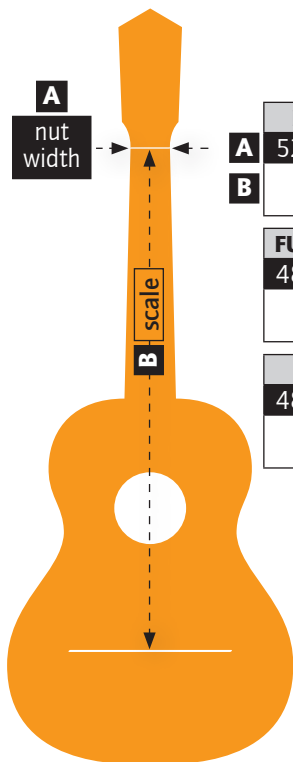

FULL SIZE
A 52 mm (2.05")
B 650 mm (25.59")

FULL SIZE SN
48 mm (1.89")
650 mm (25.59")

7/8 SIZE
48 mm (1.89")
612 mm (24.09")

BODY

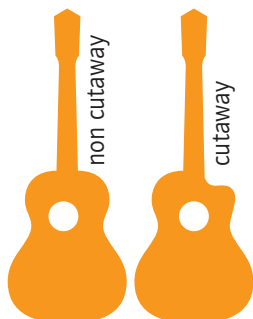

regular depth

thinline

**INCL.
DELUXE
GIG BAG**



FEATURES



Spanish heel



12hole bridge

ELECTRONICS



Preamp
(see page 109)



TRADITIONAL SERIES

MADE IN SPAIN

ortegaguitars.com

7

R180



SPANISH HEEL



scale: 650 mm (25.59")
nut width: 52 mm (2.05")



- Solid North American cedar top, satin finish
- Bubinga back & side, satin finish
- Maple top binding
- Mahogany neck, satin finish
- Rosewood fretboard & bridge
- Ortega 12hole bridge
- Handmade in Spain
- Deluxe gig bag included



SLIM NECK

NEW

scale: 650 mm (25.59")
nut width: 48 mm (1.89")



ELECTRONICS W/ TUNER
ORTEGA
MagusPRO/G

RCE180G



- Solid North American cedar top, gloss finish
- Bubinga back & side, gloss finish
- Maple top binding
- Mahogany neck, gloss finish
- Rosewood fretboard & bridge
- Ortega 12hole bridge
- MagusPRO electronics w/ tuner
- Handmade in Spain
- Deluxe gig bag included



SPANISH HEEL
SLIM NECK
THINLINE BODY DEPTH

NEW

scale: 650 mm (25.59")
nut width: 48 mm (1.89") body
depth: 75 mm (2.95")



ELECTRONICS W/ TUNER
ORTEGA
MagusPRO/G

RCE180GT



- Solid North American cedar top, gloss finish
- Bubinga back & side, gloss finish
- Maple top binding
- Mahogany neck, gloss finish
- Rosewood fretboard & bridge
- Ortega 12hole bridge
- MagusPRO electronics w/ tuner
- Body depth 75 mm (2.95")
- Handmade in Spain
- Deluxe gig bag included

R190



SPANISH HEEL

scale: 650 mm (25.59")
nut width: 52 mm (2.05")



- Solid North American cedar top, satin finish
- Caoba back & side, satin finish
- Maple binding
- Mahogany neck, satin finish
- Rosewood fretboard & bridge
- Ortega 12hole bridge
- Handmade in Spain
- Deluxe gig bag included



TRADITIONAL SERIES

MADE IN SPAIN

R200



SPANISH HEEL



scale: 650 mm (25.59")
nut width: 52 mm (2.05")



- Solid North American cedar top, gloss finish
- Palo-rojo back & side, gloss finish
- Maple binding
- Mahogany neck, gloss finish
- Rosewood fretboard & bridge
- Ortega 12hole bridge
- Handmade in Spain
- Deluxe gig bag included

R200SN



SPANISH HEEL
SLIM NECK

scale: 650 mm (25.59")
nut width: 48 mm (1.89")



- Solid North American cedar top, gloss finish
- Palo-rojo back & side, gloss finish
- Maple binding
- Mahogany neck, gloss finish
- Rosewood fretboard & bridge
- Ortega 12hole bridge
- Handmade in Spain
- Deluxe gig bag included

R220



SPANISH HEEL

scale: 650 mm (25.59")
nut width: 52 mm (2.05")



- Solid North American cedar top, gloss finish
- Mongoy back & side, gloss finish
- Maple binding
- Mahogany neck, gloss finish
- Rosewood fretboard & bridge
- Ortega 12hole bridge
- Handmade in Spain
- Deluxe gig bag included

R225G-7/8



7/8 SIZE
SPANISH HEEL



scale: 612 mm (24.09")
nut width: 48 mm (1.89")



- Solid North American cedar top, gloss finish
- Grenadillo back & side, gloss finish
- Maple binding
- Mahogany neck, gloss finish
- Rosewood fretboard & bridge
- Ortega 12hole bridge
- Handmade in Spain
- Deluxe gig bag included

TRADITIONAL SERIES

MADE IN
SPAIN

ortegaguitars.com

9

R210



SPANISH HEEL

scale: 650 mm (25.59")
nut width: 52 mm (2.05")



- Solid North American spruce top, gloss finish
- Mahogany back & side, gloss finish
- Maple binding
- Mahogany neck, gloss finish
- Rosewood fretboard & bridge
- Ortega 12hole bridge
- Handmade in Spain
- Deluxe gig bag included

R270F



FLAMENCO SPANISH HEEL

scale: 650 mm (25.59")
nut width: 52 mm (2.05")



- Solid North American spruce top, gloss finish
- Maple back & side, gloss finish
- Rosewood binding
- Mahogany neck, gloss finish
- Rosewood fretboard & bridge (flat, Flamenco)
- Flamenco scratch plates
- Ortega 12hole bridge
- Handmade in Spain
- Deluxe gig bag included

RCE270FT



FLAMENCO SPANISH HEEL THINLINE BODY DEPTH

NEW

scale: 650 mm (25.59")
nut width: 52 mm (2.05")
body depth: 75 mm (2.95")



- Solid North American spruce top, gloss finish
- Maple back & side, gloss finish
- Rosewood binding
- Mahogany neck, gloss finish
- Rosewood fretboard & bridge (flat, Flamenco)
- Flamenco scratch plates
- Ortega 12hole bridge
- Ortega/Fishman Clasica Blend System w/ jack & XLR (D.I.) output w/ tuner
- Handmade in Spain
- Deluxe gig bag included





Signature SERIES

Ben Woods
Signature models/custom made

photo: Ben Woods



**HANDMADE IN SPAIN
ALL SOLID
THINLINE FLAMENCO STYLE
SPANISH HEEL**

BWSM/2



- Solid Western Red cedar top, gloss finish
- Solid European walnut back & side, gloss finish
- Mahogany neck, gloss finish
- Sycamore body binding
- Ebony fretboard (flat) & bridge
- Flamenco double scratch plate
- Ortega 12hole bridge
- Ortega/Fishman Clasica Blend System w/ jack & XLR (D.I.) output w/ tuner
- 2way truss rod
- Handmade in Spain
- Ben Woods Signature gig bag included



scale: 650 mm (25.59")
nut width: 52 mm (2.05")
body depth: 85 mm (3.34")



ELECTRONICS W/ TUNER
ORTEGA
FISHMAN



**SUPER THINLINE
FLAMENCO STYLE
SPANISH HEEL
BUILT-IN ARMREST**

FLAMETAL-TWO



- Solid Western Red cedar top, gloss finish
- Walnut back & side, gloss finish
- SUPER Thinline body depth (72 mm high/75 low)
- Florentine Cutaway design
- Ortega Signature rosette
- Stained mahogany neck, gloss finish
- Walnut body binding/white top purfling
- Reversed headstock, 6 in line
- Pao Ferro fretboard (flat) & bridge
- Ortega 12hole bridge
- Ortega/Fishman Clasica Blend System w/ jack & XLR (D.I.) output w/ tuner
- 2way truss rod
- Mini die-cast tuners, gold w/ black buttons
- FREE Flamenco double scratch plates included
- Ben Woods Signature gig bag included



SLIM NECK

scale: 650 mm (25.59")
nut width: 48 mm (1.89")
Reversed Headstock
body depth: 75 mm (2.95")



ELECTRONICS W/ TUNER
ORTEGA
FISHMAN



Signature SERIES

Thomas Zwijsen
Signature models/custom made

photo: Thomas Supper | ortegaguitars



**HANDMADE IN SPAIN
ALL SOLID
SPANISH HEEL**

TZSM/2 

- Solid Canadian spruce top, gloss finish
- Solid spalted maple back and side, satin finish
- Mahogany neck, satin finish
- Maple binding w/ walnut support
- Maple fretboard, 12" Radius
- Ortega 6hole bridge, pao ferro
- Ortega/Fishman Clasica Blend System w/ jack & XLR (D.I.) output w/ tuner
- 2way truss rod
- Handmade in Spain
- Thomas Zwijsen Signature soft case included

SLIM NECK

scale: 650 mm (25.59")
nut width: 48 mm (1.89")



**SOLID TOP
RADIUS FRETBOARD**

TZSM-3 

- Solid Canadian spruce top, gloss finish
- Spalted maple back and side, satin finish
- Mahogany neck, satin finish
- Maple binding w/ walnut support
- Maple fretboard, 12" Radius
- Ortega 6hole bridge, pao ferro
- Ortega/Fishman Clasica Blend System w/ jack & XLR (D.I.) output w/ tuner
- 2way truss rod
- Thomas Zwijsen Signature gig bag included

SLIM NECK

scale: 650 mm (25.59")
nut width: 48 mm (1.89")





PERFORMER SERIES

OPTIONS

SCALES & SIZES

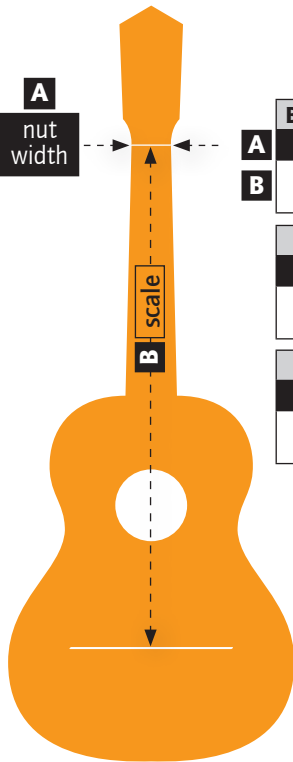

BARITONE SIZE
A 70 mm (2.75")
B 690 mm (27.16")

FULL SIZE MN
A 50 mm (1.96")
B 650 mm (25.59")

FULL SIZE SN
A 48 mm (1.89")
B 650 mm (25.59")

BODY

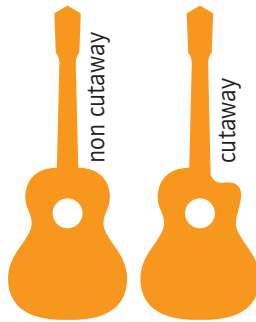

regular depth



thinline

FEATURES



Spanish heel



radiused fretboard



14th fret heel to body connection



12hole/16hole bridge



2way truss rod

ELECTRONICS



Preamp
(see page 109)

INCL. DELUXE GIG BAG



SOLID SPRUCE TOP



**SPANISH HEEL
SLIM NECK**

RCE138SN

- Solid Alaskan Sitka spruce top, gloss finish
- Sapele back & side, gloss finish
- Maple binding
- Mahogany neck, gloss finish
- Indian Laurel fretboard & bridge
- Ortega MagusPRO electronics w/ tuner
- Ortega 12hole bridge
- Ortega signature walnut/maple/white pearl rosette
- 2way truss rod
- Deluxe gig bag included



LEFT HANDED

available

scale: 650 mm (25.59")
nut width: 48 mm (1.89")

with EQ **ELECTRONICS W/ TUNER**
ORTEGA MagusPRO/G



PERFORMER SERIES SOLID SPRUCE TOP

SLIM NECK/SPANISH HEEL/RADIUS FRETBOARD



LEFT
HANDED
available



LEFT
HANDED
available



FULL SIZE

scale
650 mm (25.59")

nut width
SN = 48 mm (1.89")

body depth
85 mm (3.34")

STR = stained red
BK = black



ELECTRONICS W/ TUNER
ORTEGA
MagusPRO/G

RCE138-T4

THINLINE BODY
DEPTH
INCL. BAG



RCE138-T4STR

THINLINE BODY
DEPTH
INCL. BAG



RCE138-T4BK

THINLINE BODY
DEPTH
INCL. BAG



- Solid Alaskan Sitka spruce top, gloss finish || gloss stained red finish || gloss black finish
- Sapele back & side, gloss finish || gloss stained red finish || gloss black finish
- Maple binding

- Mahogany neck, gloss finish || gloss black finish
- 14th fret heel to body connection
- Indian Laurel radius fretboard & bridge
- Ortega MagusPRO electronics w/ tuner
- Ortega 12hole bridge

- Ortega signature walnut/maple/white pearl rosette
- 2way truss rod
- Deluxe gig bag included



MEDIUM NECK/SLIM NECK



RCE158MN

MEDIUM NECK
INCL. BAG



RCE158SN

SLIM NECK
INCL. BAG



RCE158SN-TSB

SLIM NECK
INCL. BAG



FULL SIZE

scale
650 mm (25.59")

nut width
SN = 48 mm (1.89")
MN = 50 mm (1.97")

TSB = tobacco
sunburst, top only



ELECTRONICS W/ TUNER
ORTEGA
MagusPRO/G

- Solid Alaskan Sitka spruce top, gloss finish || gloss tobacco sunburst (TSB) finish
- Walnut back & side, gloss finish
- Mahogany neck, gloss finish

- Indian Laurel fretboard & bridge
- Ortega MagusPRO electronics w/ tuner
- Ortega 12hole bridge

- Ortega signature walnut/maple/white pearl rosette
- 2way truss rod
- Deluxe gig bag included





PERFORMER SERIES SOLID CEDAR TOP



**SPANISH HEEL
MEDIUM NECK**

scale: 650 mm (25.59")
nut width: 50 mm (1.97")

with EQ ELECTRONICS W/ TUNER
ORTEGA
MagusPRO/G

**LEFT
HANDED**
available

RCE159MN **with EQ**

- Solid North American cedar top, gloss finish
- Walnut back & side, gloss finish
- Mahogany neck, gloss finish
- Indian Laurel fretboard & bridge
- Ortega MagusPRO electronics w/ tuner
- Ortega 12hole bridge
- Ortega signature walnut/maple/white pearl rosette
- 2way truss rod
- Deluxe gig bag included



**SPANISH HEEL
SLIM NECK**

scale: 650 mm (25.59")
nut width: 48 mm (1.89")

with EQ ELECTRONICS W/ TUNER
ORTEGA
MagusPRO/G

RCE159SN **with EQ**

- Solid North American cedar top, gloss finish
- Walnut back & side, gloss finish
- Mahogany neck, gloss finish
- Indian Laurel fretboard & bridge
- Ortega MagusPRO electronics w/ tuner
- Ortega 12hole bridge
- Ortega signature walnut/maple/white pearl rosette
- 2way truss rod
- Deluxe gig bag included



SPANISH HEEL

scale: 690 mm (27.16")
nut width: 70 mm (2.75")

with EQ ELECTRONICS
ORTEGA
MagusGO-8

RCE159-8 **with EQ**

- 8string NYLON STRING GUITAR
- Solid North American cedar top, gloss finish
- Walnut back & side, gloss finish
- Mahogany neck, gloss finish
- Tecwood fretboard (flat, 70 mm at nut / 78 mm on 14th fret / 90 mm on saddle)
- Tecwood bridge
- MagusGO-8 electronics
- Ortega 16hole bridge
- Ortega signature walnut/maple/white pearl rosette
- 2way truss rod
- Deluxe gig bag included



PERFORMER SERIES SOLID SPRUCE TOP



**BLACK TOP
SPANISH HEEL
SLIM NECK**

NEW

RE238SN-BKT 

scale: 650 mm (25.59")
nut width: 48 mm (1.89")

 **ELECTRONICS W/ TUNER**
ORTEGA
MagusGO



- Solid Alaskan Sitka spruce top, gloss black finish
- Mahogany back & side, gloss finish
- Mahogany neck, gloss finish
- Indian Laurel fretboard & bridge
- Ortega MagusGO electronics
- Ortega 12hole bridge
- Ortega signature rosette walnut/maple/white pearl
- 2way truss rod
- Deluxe gig bag included



**BLACK TOP
SPANISH HEEL
SLIM NECK**

NEW

RCE238SN-BKT 

scale: 650 mm (25.59")
nut width: 48 mm (1.89")

 **ELECTRONICS W/ TUNER**
ORTEGA
MagusPRO/G

6 IN LINE LOCKING MACHINES



- Solid Alaskan Sitka spruce top, gloss black finish
- Mahogany back & side, gloss finish
- Mahogany neck, gloss finish
- Indian Laurel fretboard & bridge
- Ortega OTMLOCK6L-CR locking tuning machines
- Ortega MagusPRO electronics w/ tuner
- Ortega 12hole bridge
- Ortega signature rosette walnut/maple/white pearl
- 2way truss rod
- Deluxe gig bag included



**BURST TOP
SPANISH HEEL
SLIM NECK**

RCE238SN-FT 

scale: 650 mm (25.59")
nut width: 48 mm (1.89")

 **ELECTRONICS W/ TUNER**
ORTEGA
MagusPRO/G



6 IN LINE LOCKING MACHINES



- Solid Alaskan Sitka spruce top, gloss burst finish
- Mahogany back & side, gloss finish
- Mahogany neck, gloss finish
- Indian Laurel fretboard & bridge
- Ortega OTMLOCK6L-CR locking tuning machines
- Ortega MagusPRO electronics w/ tuner
- Ortega 12hole bridge
- Ortega signature rosette walnut/maple/white pearl
- 2way truss rod
- Deluxe gig bag included





FAMILY SERIES PRO

OPTIONS

SCALES & SIZES

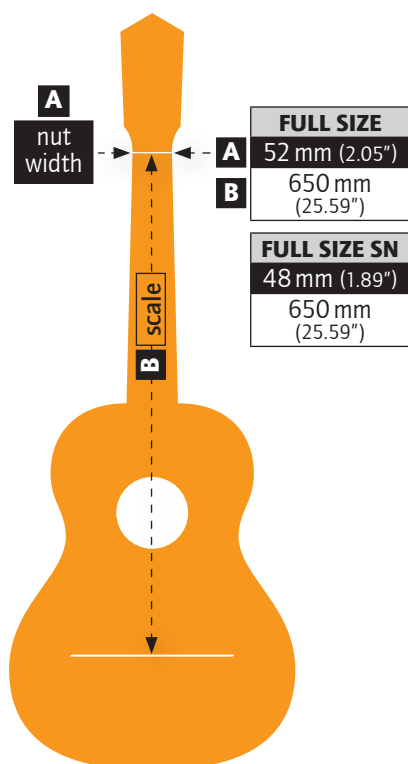

BODY

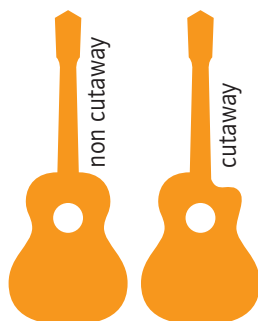

INCL. DELUXE GIG BAG
(for selected models)

FEATURES



12hole bridge



2way truss rod

ELECTRONICS



Electronics
(see page 109)



SOLID SPRUCE TOP



R55



R55BFT



R55DLX
ARMREST



R55DLX-BFT
ARMREST

FULL SIZE

scale
650 mm (25.59")

nut width
52 mm (2.05")

BFT = Bourbon burst top

- Solid Engelmann spruce top, natural satin finish (R55) || satin bourbon burst finish (R55BFT)
- Solid Engelmann spruce top, natural semi gloss finish (R55DLX) || semi gloss bourbon burst finish (R55DLX-BFT)

- Catalpa back & side, satin finish (R55 & R55BFT) || semi gloss finish (R55DLX & R55DLX-BFT)
- Nato neck, satin finish (R55 & R55BFT) || semi gloss satin finish (R55DLX & R55DLX-BFT)
- 2way truss rod

- Black ABS binding (R55 & R55BFT) || Rosewood style ABS binding
- Walnut headstock veneer
- Walnut fretboard & bridge
- Armrest (R55DLX & R55DLX-BFT)

FAMILY SERIES PRO SOLID CEDAR/SPRUCE TOP

SOLID CEDAR TOP



R131
INCL. BAG

RCE131
INCL. BAG

R131SN
SLIM NECK
INCL. BAG

RCE131SN
SLIM NECK
INCL. BAG

R131SN-WR
SLIM NECK
INCL. BAG

- Solid Canadian Western Red cedar top, satin finish || gloss wine red finish (transparent)
- Mahogany back & side, satin finish || gloss wine red finish (transparent)
- Mahogany neck, satin finish || gloss wine red finish (transparent)
- Walnut fretboard & bridge
- Ortega MagusPRO electronics w/ tuner (RCE131, RCE131SN)
- Ortega 12hole bridge
- 2way truss rod
- Deluxe gig bag included



ELECTRONICS W/ TUNER
ORTEGA
MagusPRO/G

	scale	nut width
FULL SIZE SN	650 mm (25.59")	48 mm (1.89")
FULL SIZE	650 mm (25.59")	52 mm (2.05")

SOLID SPRUCE TOP



RCE141BK
INCL. BAG

RCE145BK
SLIM NECK
THINLINE BODY DEPTH
INCL. BAG

RCE145WH
SLIM NECK
THINLINE BODY DEPTH
INCL. BAG

RCE145xx
body depth
85 mm (3.34")

- Solid Canadian Engelmann spruce top, gloss black finish || gloss white finish
- Mahogany back & side, gloss black finish || gloss white finish
- Mahogany neck, gloss black finish || gloss white finish
- Walnut fretboard (flat) & bridge
- Ortega MagusPRO electronics w/ tuner
- Ortega 12hole bridge
- 2way truss rod
- Deluxe gig bag included



ELECTRONICS W/ TUNER
ORTEGA
MagusPRO/G

	scale	nut width
FULL SIZE (SLIM NECK)	650 mm (25.59")	48 mm (1.89")
FULL SIZE	650 mm (25.59")	52 mm (2.05")

BK = black | **WH** = white



FAMILY SERIES

OPTIONS

SCALES & SIZES

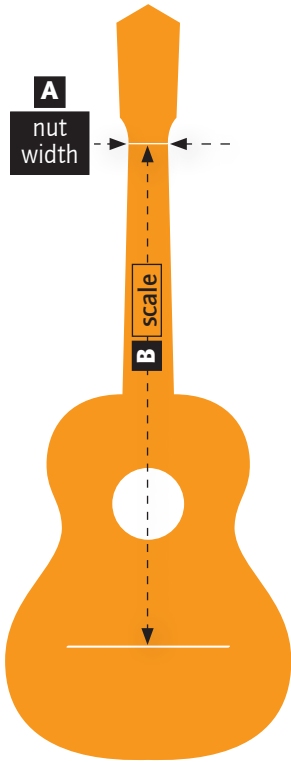

FULL SIZE	
A	52 mm (2.05")
B	650 mm (25.59")
FULL SIZE SN	
	48 mm (1.89")
	650 mm (25.59")
7/8 SIZE	
	47 mm (1.85")
	615 mm (24.21")
3/4 SIZE	
	45 mm (1.77")
	590 mm (23.23")
1/2 SIZE	
	43.5 mm (1.71")
	560 mm (22.05")
1/4 SIZE	
	43.5 mm (1.71")
	438 mm (17.24")

BODY

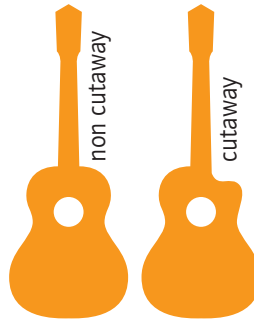

FEATURES



12hole bridge

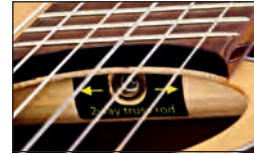

2way truss rod

INCL. DELUXE GIG BAG
(for selected models)



ELECTRONICS



ORTEGA
MagusPRO/G

Electronics
(see page 109)





**FULL SIZE
SLIM NECK
THINLINE BODY**

scale: 650 mm (25.59")
nut width: 48 mm (1.89")
body depth: 85 mm (3.34")

with EQ ELECTRONICS W/ TUNER
ORTEGA
MagusPRO/G

**LEFT
HANDED**
available

RCE125SN **with EQ**



- Spruce top, satin finish
- Mahogany back & side, satin finish
- Maple binding
- Mahogany neck, satin finish
- Walnut fretboard & bridge
- Ortega MagusPRO electronics w/ tuner
- Ortega 12hole bridge
- 2way truss rod
- Deluxe gig bag included



**FULL SIZE
SLIM NECK
THINLINE BODY**

scale: 650 mm (25.59")
nut width: 48 mm (1.89")
body depth: 85 mm (3.34")

with EQ ELECTRONICS W/ TUNER
ORTEGA
MagusPRO/G

RCE125SN-SBK **with EQ**



- Spruce top, satin black finish
- Mahogany back & side, satin black finish
- White ABS binding
- Mahogany neck, satin black finish
- Walnut fretboard & bridge
- Ortega MagusPRO electronics w/ tuner
- Ortega 12hole bridge
- 2way truss rod
- Deluxe gig bag included



**FULL SIZE
SLIM NECK
THINLINE BODY**

scale: 650 mm (25.59")
nut width: 48 mm (1.89")
body depth: 85 mm (3.34")

with EQ ELECTRONICS W/ TUNER
ORTEGA
MagusPRO/G

RCE125MMSN **with EQ**



- Mahogany top, satin finish
- Mahogany back & side, satin finish
- Black ABS binding
- Mahogany neck, satin finish
- Walnut fretboard & bridge
- Ortega MagusPRO electronics w/ tuner
- Ortega 12hole bridge
- 2way truss rod
- Deluxe gig bag included





FAMILY SERIES SPRUCE/CEDAR TOP ALL GLOSS



3/4 SIZE

NEW

scale: 590 mm (23.23")
nut width: 45 mm (1.77")

R121G-3/4



- Spruce top, gloss finish
- Mahogany back & side, gloss finish
- Mahogany neck, gloss finish
- Walnut fretboard & bridge
- Ortega 12hole bridge
- 2way truss rod
- Deluxe gig bag included



FULL SIZE

NEW

scale: 650 mm (25.59")
nut width: 52 mm (2.05")

R121G



- Spruce top, gloss finish
- Mahogany back & side, gloss finish
- Mahogany neck, gloss finish
- Walnut fretboard & bridge
- Ortega 12hole bridge
- 2way truss rod
- Deluxe gig bag included



3/4 SIZE

NEW

scale: 590 mm (23.23")
nut width: 45 mm (1.77")

R122G-3/4



- Cedar top, gloss finish
- Mahogany back & side, gloss finish
- Mahogany neck, gloss finish
- Walnut fretboard & bridge
- Ortega 12hole bridge
- 2way truss rod
- Deluxe gig bag included



FULL SIZE

NEW

scale: 650 mm (25.59")
nut width: 52 mm (2.05")

R122G



- Cedar top, gloss finish
- Mahogany back & side, gloss finish
- Mahogany neck, gloss finish
- Walnut fretboard & bridge
- Ortega 12hole bridge
- 2way truss rod
- Deluxe gig bag included



- Spruce top, satin finish (R121xx) || Cedar top, satin finish (R122xx)
- Mahogany back & side, satin finish
- Mahogany neck, satin finish
- Walnut fretboard & bridge
- Ortega 12hole bridge

- 2way truss rod (1/2, 3/4, 7/8 & full size)
- Deluxe gig bag included



	scale	nut width
1/4 SIZE	438 mm (17.24")	43.5 mm (1.71")
1/2 SIZE	560 mm (22.05")	43.5 mm (1.71")
3/4 SIZE	590 mm (23.23")	45 mm (1.77")
7/8 SIZE	615 mm (24.21")	47 mm (1.85")
FULL SIZE SN	650 mm (25.59")	48 mm (1.89")
FULL SIZE	650 mm (25.59")	52 mm (2.05")



FAMILY SERIES SPRUCE TOP



NEW

R121-3/4OC
3/4 SIZE
INCL. BAG



NEW

R121SNOC
FULL SIZE
SLIM NECK / INCL. BAG

- Spruce top, gloss ocean blue finish
- Mahogany back & side, gloss ocean blue finish
- Mahogany neck, gloss ocean blue finish
- Walnut fretboard & bridge
- Ortega 12hole bridge
- 2way truss rod
- Deluxe gig bag included



	scale	nut width
3/4 SIZE	590 mm (23.23")	45 mm (1.77")
FULL SIZE SN	650 mm (25.59")	48 mm (1.89")

OC = ocean blue



R121-1/4WR
1/4 SIZE
INCL. BAG



R121-1/2WR
1/2 SIZE
INCL. BAG



R121-3/4WR
3/4 SIZE
INCL. BAG



R121-7/8WR
7/8 SIZE
INCL. BAG



R121WR
FULL SIZE
INCL. BAG

LEFT
HANDED
available

- Spruce top, gloss wine red finish
- Mahogany back & side, gloss wine red finish
- Mahogany neck, gloss wine red finish
- Walnut fretboard & bridge
- Ortega 12hole bridge
- 2way truss rod (1/2, 3/4, 7/8 & full size)
- Deluxe gig bag included



	scale	nut width
1/4 SIZE	438 mm (17.24")	43.5 mm (1.71")
1/2 SIZE	560 mm (22.05")	43.5 mm (1.71")
3/4 SIZE	590 mm (23.23")	45 mm (1.77")
7/8 SIZE	615 mm (24.21")	47 mm (1.85")
FULL SIZE	650 mm (25.59")	52 mm (2.05")

WR = wine red

FAMILY SERIES SPRUCE TOP



R221BK-3/4
3/4 SIZE
INCL. BAG



R221BK-7/8
7/8 SIZE
INCL. BAG



R221SNBK
FULL SIZE
SLIM NECK / INCL. BAG



R221BK
FULL SIZE
INCL. BAG



- Spruce top, gloss black finish
- Mahogany back & side, gloss black finish
- Mahogany neck, gloss black finish
- Walnut fretboard & bridge
- Mahogany body & fretboard binding

- White abalone style purfling
- Ortega 12hole bridge
- 2way truss rod
- Deluxe gig bag included



	scale	nut width
3/4 SIZE	590 mm (23.23")	45 mm (1.77")
7/8 SIZE	615 mm (24.21")	47 mm (1.85")
FULL SIZE SN	650 mm (25.59")	48 mm (1.89")
FULL SIZE	650 mm (25.59")	52 mm (2.05")

BK = black



R121-1/2WH
1/2 SIZE
INCL. BAG



R121-3/4WH
3/4 SIZE
INCL. BAG



R121WH
FULL SIZE
INCL. BAG



R121SNWH
FULL SIZE
SLIM NECK / INCL. BAG

- Spruce top, gloss white finish
- Mahogany back & side, gloss white finish
- Mahogany neck, gloss white finish
- Walnut fretboard & bridge
- Ortega 12hole bridge

- 2way truss rod
- Deluxe gig bag included



	scale	nut width
1/2 SIZE	560 mm (22.05")	43.5 mm (1.71")
3/4 SIZE	590 mm (23.23")	45 mm (1.77")
FULL SIZE SN	650 mm (25.59")	48 mm (1.89")
FULL SIZE	650 mm (25.59")	52 mm (2.05")

WH = white



STUDENT SERIES

OPTIONS

SCALES & SIZES

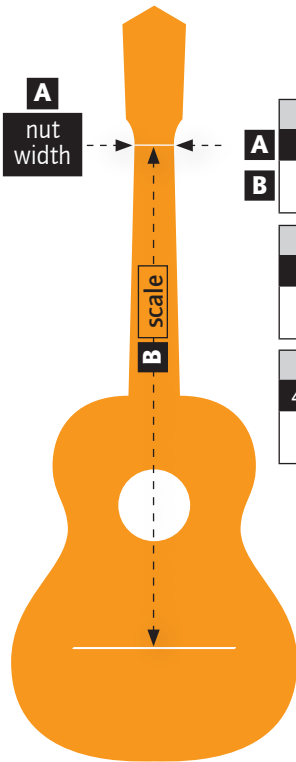

A	FULL SIZE
nut width	52 mm (2.05")
B	650 mm (25.59")
	3/4 SIZE
scale	45 mm (1.77")
	590 mm (23.23")
	1/2 SIZE
	43.5 mm (1.71")
	560 mm (22.05")

BODY



FEATURES



6hole bridge



classical tuning machines



SPRUCE TOP



RST5-1/2
1/2 SIZE



RST5-3/4
3/4 SIZE



RST5
FULL SIZE

- Spruce top, gloss finish
- Catalpa back & side, gloss finish
- ABS binding
- Mahogany neck, gloss finish
- Walnut fretboard & bridge
- Ortega 6hole bridge

	scale	nut width
1/2 SIZE	560 mm (22.05")	43.5 mm (1.71")
3/4 SIZE	590 mm (23.23")	45 mm (1.77")
FULL SIZE	650 mm (25.59")	52 mm (2.05")



RST5M
FULL SIZE

RSTC5M-3/4
3/4 SIZE

RSTC5M
FULL SIZE

- Spruce top (RST5M) || Cedar top, satin finish (RSTC5M-3/4 & RSTC5M)
- Catalpa back & side
- Pinstripe rosette (RST5M) || Classical rosette (RSTC5M-3/4 & RSTC5M)
- ABS binding
- Mahogany neck
- Walnut fretboard & bridge
- Ortega 6hole bridge

	scale	nut width
3/4 SIZE	590 mm (23.23")	45 mm (1.77")
FULL SIZE	650 mm (25.59")	52 mm (2.05")

M = matte satin finish



RST5M-3/4OC
3/4 SIZE

RST5MOC
FULL SIZE

RST5M-3/4BK
3/4 SIZE

RST5MBK
FULL SIZE

- Spruce top, satin ocean blue finish (RST5M-3/4OC & RST5MOC) || Spruce top, satin black finish (RST5M-3/4BK & RST5MBK)
- Catalpa back & side, satin ocean blue finish (RST5M-3/4OC & RST5MOC) || Catalpa back & side, satin black finish (RST5M-3/4BK & RST5MBK)
- Pinstripe rosette
- ABS binding
- Mahogany neck, satin ocean blue finish (RST5M-3/4OC & RST5MOC) || Mahogany neck, satin black finish (RST5M-3/4BK & RST5MBK)
- Walnut fretboard & bridge
- Ortega 6hole bridge

	scale	nut width
3/4 SIZE	590 mm (23.23")	45 mm (1.77")
FULL SIZE	650 mm (25.59")	52 mm (2.05")

OC = ocean blue
MBK = satin black finish



GAUCHO SERIES

OPTIONS

SCALES & SIZES

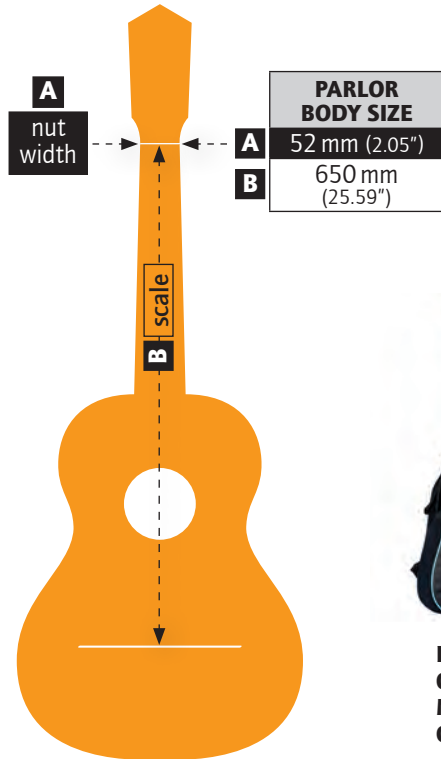

INCL. COLOR MATCHING GIG BAG



PARLOR BODY



RGA-SKY
INCL. BAG



RGA-PLT
INCL. BAG



RGA-ORG
INCL. BAG



RGA-GAP
INCL. BAG

- Agathis top (sky blue, platinum gray, orange, green apple), gloss finish
- Agathis back & side (sky blue, platinum gray, orange, green apple), gloss finish
- Parlor body
- Ivory ABS binging
- Nato neck, gloss finish, 2way truss rod

- Walnut fretboard & bridge
- Maple "bars" fretboard inlays
- Chrome tuning machines w/ white buttons
- Tear drop pickguard
- Color matching gig bag included

PARLOR BODY SIZE	scale	nut width
FULL SIZE	650 mm (25.59")	52 mm (2.05")

SKY = sky blue
ORG = orange
GAP = green apple
PLT = platinum gray

OPTIONS

SCALES & SIZES

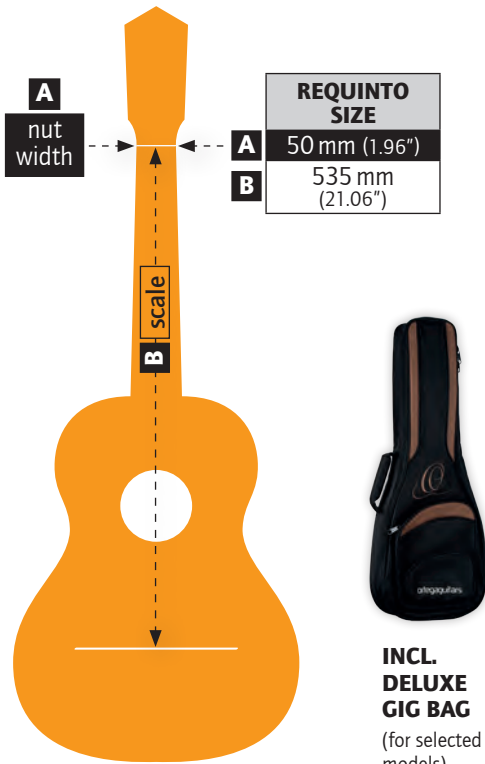

DEEP BODY SPRUCE/CEDAR TOP



RQ25

RQC25

REQUINTO SIZE

scale
535 mm (21.06")

nut width
50 mm (1.96")

DEEP BODY MEDIUM NECK

- Spruce top, satin natural finish (RQ25) || Cedar top, satin natural finish (RQC25)
- Sapele back & side, satin finish
- 110 mm body depth, extra deep

- Okoume neck, satin finish, 2way truss rod
- Walnut headstock veneer
- Walnut fretboard & bridge

DEEP BODY SOLID ENGELMANN SPRUCE TOP/ SOLID CEDAR TOP



RQ38

INCL. BAG

RQ39

INCL. BAG

RQ39E

INCL. BAG



REQUINTO SIZE

scale
535 mm (21.06")

nut width
50 mm (1.96")

DEEP BODY MEDIUM NECK

- Solid Engelmann Spruce top, satin natural finish (RQ38) || Solid Cedar top, satin natural finish (RQ39)
- Sapele back & side, satin finish
- 110 mm body depth, extra deep
- Okoume neck, satin finish, 2way truss rod

- Walnut headstock veneer
- Walnut fretboard & bridge
- Ortega MagusGo preamp & pickup (RQ39E)
- Deluxe gig bag included





MINI | TRAVEL SERIES OPTIONS

SCALES & SIZES

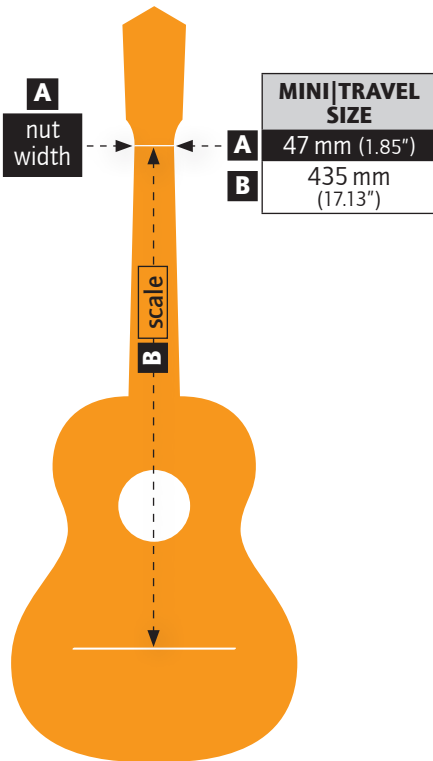

BODY

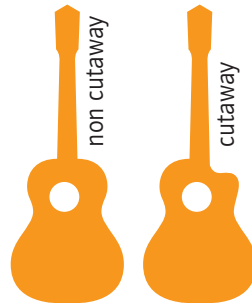

ELECTRONICS



Electronics
(see page 109)

TUNING

Mini | Travel Guitars are usually E or A tuned. We prefer an A tuning. Our Mini | Travel Guitars are tuned: A-D-G-C-E-A

INCL. DELUXE GIG BAG
(for selected models)



SATIN FINISH



RGL5

MINI | TRAVEL



RGL5CE

MINI | TRAVEL



ELECTRONICS W/ TUNER
ORTEGA MagusUke

MINI | TRAVEL

scale
435 mm (17.13")

nut width
47 mm (1.85")



RGL5EB

MINI | TRAVEL



RGL5EB-CE

MINI | TRAVEL



- Spruce top, satin finish, laser engraved motif
- Mahogany back & side, satin finish
- Mahogany neck, satin finish

- 18 frets
- Ortega MagusUke electronics w/ tuner (RGL5CE)
- Walnut fretboard & bridge

- Ebony top, satin open pore finish
- Ebony back & side, satin open pore finish
- Mahogany neck, satin finish
- Ebony headstock veneer
- Tortoise style binding & tortoise style rosette

- 18 frets
- Walnut fretboard & bridge
- Ortega MagusUke electronics w/ tuner (RGL5EB-CE)
- Die-cast tuning machines, gold w/ black buttons

MINI | TRAVEL SERIES

ALL GLOSS FINISH



SOLID TOP
MINI | TRAVEL

NEW

RGLE18ACA 

scale: 435 mm (17.13")
nut width: 47 mm (1.85")

 **ELECTRONICS W/ TUNER**
ORTEGA
MagusUke



- Solid acacia top, gloss finish
- Acacia back & side, gloss finish
- Mahogany neck, gloss finish
- Abalone style rosette
- Walnut fretboard & bridge
- Divided back w/ maple stripe inlays
- 18 frets
- Ortega MagusUke electronics w/ tuner
- Open tuning machines, gold w/ marbled style buttons
- Deluxe gig bag included



MINI | TRAVEL

RGLE18FMH 

scale: 435 mm (17.13")
nut width: 47 mm (1.85")

 **ELECTRONICS W/ TUNER**
ORTEGA
MagusUke



- Flamed mahogany top, gloss finish
- Flamed mahogany back & side, gloss finish
- Mahogany neck, satin finish
- Walnut fretboard & bridge
- 18 frets
- Ortega MagusUke electronics w/ tuner
- Open tuning machines, gold w/ white buttons
- Deluxe gig bag included



MINI | TRAVEL

RGLE18BLF 

scale: 435 mm (17.13")
nut width: 47 mm (1.85")

 **ELECTRONICS W/ TUNER**
ORTEGA
MagusUke



- Flamed mahogany top, gloss blue burst finish
- Flamed mahogany back & side, gloss blue burst finish
- Mahogany neck, gloss finish
- Walnut fretboard & bridge
- 18 frets
- Ortega MagusUke electronics w/ tuner
- Open tuning machines, gold w/ white buttons
- Deluxe gig bag included





THE PRIVATE ROOM

CUSTOM CRAFTED INSTRUMENTS

|| The Private Room starts with handpicked tonewoods that are set aside to be custom crafted into exclusive guitars. This selection is limited and truly unique. ||

SPALTED SUITE



RSM-REISSUE

**AAA SPALTED MAPLE
BACK & SIDE**

scale: 650 mm
nut width: 48 mm

SN
(slim neck)



- Spalted maple top, natural semi gloss finish
- Spalted maple back & side, natural semi gloss finish
- Nato neck, natural semi gloss finish
- Sapele & Black ABS top and bottom binding
- Spalted maple headstock veneer
- Walnut fretboard w/ sapele binding
- Walnut bridge, satin
- 2way truss rod
- Chrome tuning machines w/ black posts and buttons
- ABS nut & saddle
- Deluxe gig bag included

ECLIPSE SUITE



ECLIPSESU.C/E 
BUILT-IN ARMREST

 **ELECTRONICS W/ TUNER**
ORTEGA
MagusPRO/G

**ALL
MAHOGANY**

scale: 650 mm
nut width: 48 mm

SN
(slim neck)



- Solid mahogany top, eclipse burst gloss finish
- Mahogany back & side, gloss finish
- Walnut top & back binding/MOP purfling
- Walnut armrest
- Mahogany neck, gloss finish
- Indian Laurel fretboard (flat) & bridge
- 2way truss rod
- Spanish heel
- Eclipse soundhole design
- Eclipse fretboard inlay
- Ortega 12hole bridge
- A class tuning machines matte brass/black w/ black buttons
- Ortega MagusPRO electronics w/ tuner
- Deluxe gig bag included

STRIPED SUITES



STRIPEDSU.C/E 

BUILT-IN ARMREST

 **ELECTRONICS W/ TUNER**
ORTEGA
MagusPRO/G

AAA STRIPED EBONY BACK & SIDE

scale: 650 mm **SN**
nut width: 48 mm (slim neck)



- Solid Alaskan spruce top, gloss finish
- AAA striped ebony back & side, gloss finish
- Acacia binding/ white purfling
- Mahogany neck, gloss finish
- Indian Laurel fretboard (flat) & bridge
- 2way truss rod
- Spanish heel
- Ortega signature walnut/maple/white pearl rosette
- Ortega 12hole bridge
- A class tuning machines matte brass/black w/ black buttons
- Ortega MagusPRO electronics w/ tuner
- Deluxe gig bag included



STRIPEDSU.ACB 

BUILT-IN ARMREST 4STRING ACOUSTIC BASS

available

 **ELECTRONICS W/ TUNER**
ORTEGA
MagusPRO/B

AAA STRIPED EBONY BACK & SIDE

medium scale: 812 mm (32")
nut width: 45 mm (1.77")
body depth: 122 mm (4.8")



- 4string acoustic bass
- Solid Alaskan spruce top, gloss finish
- AAA striped ebony back & side, gloss finish
- Acacia top & bottom binding/ white purfling
- Mahogany neck, gloss finish
- Medium scale
- Tecwood fretboard w/ walnut binding
- Tecwood bridge
- 2way truss rod
- Ortega signature walnut/maple/white pearl rosette
- Ortega die-cast tuning machines, gold
- Ortega MagusPRO electronics w/ tuner
- Deluxe gig bag included

DISTRESSED SUITES



DSSUITE-UKE 

 **ELECTRONICS W/ TUNER**
ORTEGA
MagusUke

DISTRESSED SATIN FINISH

scale: 376 mm (14.80")
nut width: 35 mm (1.38")



- Solid Alaskan spruce top, distressed tobacco satin finish
- Mahogany back & side, distressed tobacco satin finish
- Reversed headstock, 4 in line
- Okoume neck, satin finish
- No body binding, walnut fretboard binding
- Tecwood fretboard & bridge
- Ortega MagusUke electronics w/ tuner
- Die-cast tuning machines black, black, chrome, black
- Deluxe gig bag included



DSSUITE-C/E 

THINLINE BODY

 **ELECTRONICS W/ TUNER**
ORTEGA
MagusPRO/G

DISTRESSED SATIN FINISH

scale: 650 mm **SN & DTS**
nut width: 48 mm (slim neck & distressed tobacco sunburst finish)



- Solid Alaskan spruce top, DTS, satin finish
- Mahogany back & side, DTS, satin finish
- No body binding, walnut fretboard binding
- Mahogany neck, distressed tobacco sunburst, satin
- Heel to body connection on 14th fret
- Indian Laurel fretboard (radius, 400R) with „XII“ inlay on 12th fret
- 2way truss rod
- Spanish heel
- Ortega signature walnut/maple/white pearl rosette
- Ortega 12hole bridge, walnut
- Aged vintage tuning machines, classic 3 bar
- Ortega MagusPRO electronics w/ tuner
- Deluxe gig bag included



INDEX

ORTEGA® UKULELES	32
Elite Series	33
Bonfire Series	34
Art Series	35
Earth Series	36
Onyx Series	37
Element Series	37
Gaucho Series	38
Horizon Series	38
The Private Room	38
Bamboo Series	40
Timber Series	41
Prism Series	44
Lizard Series	44
Banjolele Series	45
Custom Built Series	46
UKEBASSES	48
Bamboo Series	48
Lizard Series	49
Custom Built Series	49

UKULELES

ALL SERIES OPTIONS

SCALES & SIZES

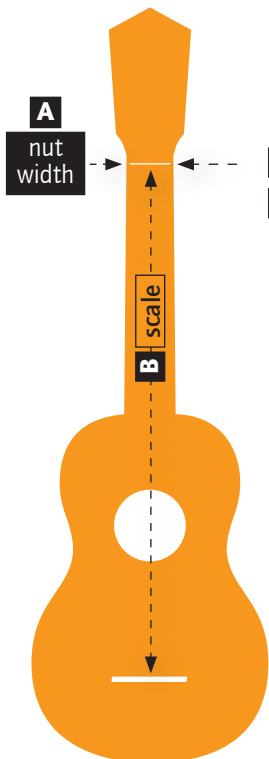

BARITONE
38 mm (1.49")
485/510 mm (19.09"/20.08")

TENOR
35 mm (1.38")
440/432/430 mm (17.32"/17.00"/16.93")

A	37 mm (1.46")
B	440/432/430 mm (17.32"/17.00"/16.93")

38 mm (1.49")
440/432/430 mm (17.32"/17.00"/16.93")

CONCERT
35 mm (1.38")
380/376 mm (14.96"/14.80")

36 mm (1.42")
380/376 mm (14.96"/14.80")

38 mm (1.49")
380/376 mm (14.96"/14.80")

SOPRANO
35 mm (1.38")
350/346/344 mm (13.78"/13.76"/13.54")

36 mm (1.42")
350/346/344 mm (13.78"/13.76"/13.54")

BODY

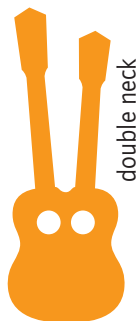
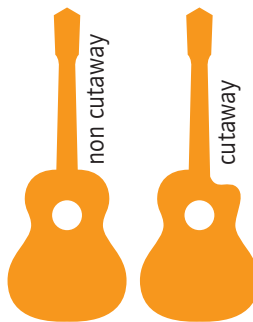

TUNING

BA = D-G-B-E
 TE/CC/SO = G-C-E-A
 8string TE = Gg-Cc-Ee-Aa
 BS = E-A-D-G

FEATURES



Preinstalled strap button on all Ortega ukuleles

ELECTRONICS

ORTEGA® MagusUke

ORTEGA® MagusFly

Electronics w/ tuner (see page 109)

INCL. DELUXE/ELITE GIG BAG

(for selected models)



SOLID TOP



CONCERT

scale
380 mm (14.96")

nut width
36 mm (1.42")



NEW

RUET-QMA 
INCL. BAG



NEW

RUET-ZC 
INCL. BAG



NEW

RUET-SMA 
INCL. BAG



MagusFly
Rechargeable
Preamp

- Solid Quilted Maple (QMA) || Solid Zircote (ZC) || Solid Spalted Maple (SMA) || Solid Acacia (ACA) || Solid Ebony (EB) top, gloss finish
- Quilted Maple || Zircote || Spalted Maple || Acacia || Ebony back & side, gloss finish
- Mahogany neck, gloss finish
- Scalloped cutaway
- Mahogany/Maple body binding
- Walnut fretboard & bridge
- Abalone style "tree of life" fretboard inlay
- Mahogany rosette w/ abalone style inlays
- MagusFly electronics w/ soundhole controls, phase switch and strap button preamp output jack
- Graph Tech® Ratio friction tuning machines black w/ black buttons
- Elite gig bag included



NEW

RUET-ACA 
INCL. BAG



NEW

RUET-EB 
INCL. BAG



BONFIRE SERIES



ELECTRONICS W/ TUNER

ORTEGA
MagusUke



RU5-SO
SOPRANO



RU5
CONCERT

LEFT
HANDED
available



RU5CE
CONCERT

LEFT
HANDED
available



RUPA5
CONCERT



RU5-TE
TENOR



RU5CE-TE
TENOR



RU5-BA
BARITONE



RU5CE-BA
BARITONE



- Spruce top, satin finish, laser engraved motif
- Sapele back & side, satin finish
- Mahogany neck, satin finish
- Tortoise style ABS binding

- Walnut fretboard & bridge
- Ortega MagusUke electronics w/ tuner (RU5CE, RU5CE-TE & RU5CE-BA)
- Die-cast tuning machines, chrome w/ black buttons

	scale	nut width
SOPRANO	350 mm (13.78")	36 mm (1.42")
CONCERT	380 mm (14.96")	36 mm (1.42")
TENOR	440 mm (17.32")	37 mm (1.45")
BARITONE	485 mm (19.09")	38 mm (1.49")

BONFIRE SERIES



RU5MM-SO
SOPRANO



RU5MM
CONCERT

LEFT
HANDED
available



RUPA5MM
CONCERT



RU5MM-CE 
CONCERT



RU5MM-TE
TENOR

- Sapele top, satin finish, laser engraved motif
- Sapele back & side, satin finish
- Mahogany neck, satin finish
- Tortoise style ABS binding

- Walnut fretboard & bridge
- Die-cast tuning machines, chrome w/ black buttons
- Ortega MagusUke electronics w/ tuner (RU5MM-CE)

	scale	nut width
SOPRANO	350 mm (13.78")	36 mm (1.42")
CONCERT	380 mm (14.96")	36 mm (1.42")
TENOR	440 mm (17.32")	37 mm (1.46")
BARITONE	485 mm (19.09")	38 mm (1.49")

ART SERIES



RUAR-BI

NEW



RUAR-EY

NEW



RUAR-MI

NEW



RUAR-HY

NEW

- Spruce top, custom designed "Birds" (BI) || "Egypt" (EY) || "Mystic India" (MI) || "Himalaya" (HY) satin finish
- Catalpa back & side, satin finish
- Nato neck, satin finish

- Catalpa headstock veneer
- Maple fretboard & bridge
- Die-cast tuning machines, gold w/ gold buttons

	scale	nut width
CONCERT	380 mm (14.96")	36 mm (1.42")



EARTH SERIES



ELECTRONICS W/ TUNER

ORTEGA
MagusUke



**RUDAWN
CONCERT**



RUDAWN-CE



RUCOAL



RUCOAL-CE



RUOCEAN



RUOCEAN-CE



RUUKI



RUUKI-CE



RURUBY

	scale	nut width
CONCERT	380 mm (14.96")	36 mm (1.42")

- Okoume top, back & side, dawn sunburst (coal black, ocean blue, hokkaido orange, ruby raspberry, forest green, lagoon turquoise, fire red) satin finish
- Mahogany neck
- Matching headstock veneer, satin finish
- White ABS binding
- Walnut fretboard & bridge
- Ortega MagusUke electronics w/ tuner (-CE)
- Die-cast tuning machines, chrome



RURUBY-CE



RUFORST



RULAGOON



RUFIRE

ONYX SERIES

SLOTTED HEADSTOCK



NEW

RUOX-SO
SOPRANO
INCL. BAG



NEW

RUOX-CC
CONCERT
INCL. BAG



NEW

RUOX-TE
TENOR
INCL. BAG

- Spruce top, gloss black finish
- Mahogany back & side, gloss black finish
- Mahogany neck, gloss black finish
- Slotted Headstock
- Mahogany body & fretboard binding, white pearl purfling
- Tecwood fretboard & bridge
- Mahogany rosette
- Walnut headstock veneer, gloss finish
- Tuning machines, gold w/ black buttons
- Deluxe gig bag included



	scale	nut width
SOPRANO	350 mm (13.78")	36 mm (1.42")
CONCERT	380 mm (14.96")	36 mm (1.42")
TENOR	440 mm (17.32")	37 mm (1.45")

ELEMENT SERIES

METALLIC TOP



NEW

RUEL-MRD
INCL. BAG



NEW

RUEL-MBL
INCL. BAG



NEW

RUEL-MBK
INCL. BAG



NEW

RUEL-MGR
INCL. BAG

- Spruce top, metallic red (MRD) || metallic blue (MBL) || metallic black (MBK) || metallic green (MGR), gloss finish
- Catalpa back & side, satin finish
- Mahogany neck, satin finish
- Matching headstock veneer, gloss finish
- Ivory ABS body & fretboard binding
- Tecwood fretboard & bridge
- Element fretboard inlay
- Die-cast tuning machines, gold w/ black buttons
- Deluxe gig bag included



	scale	nut width
CONCERT	380 mm (14.96")	36 mm (1.42")

MRD = metallic red
MBL = metallic blue
MBK = metallic black
MGR = metallic green



GAUCHO SERIES



RUGA-SKY
INCL. BAG



RUGA-PLT
INCL. BAG



RUGA-ORG
INCL. BAG



RUGA-GAP
INCL. BAG

- Agathis top, back & side (sky blue, platinum gray, orange, green apple) gloss finish
- Ivory ABS binding
- Okoume neck, gloss finish
- Slotted head, Okoume veneer
- Walnut fretboard & bridge

- Maple "bars" fretboard inlays
- Chrome tuning machines w/ white buttons
- Tear drop pickguard
- Color matching gig bag included

	scale	nut width
TENOR	432 mm (17.00")	37 mm (1.49")

SKY = sky blue
PLT = platinum gray
ORG = orange
GAP = green apple

HORIZON SERIES



RUHZ-CE-STAR



CONCERT scale: 376 mm (14.80")
nut width: 35 mm (1.38")



- Agathis top, gloss "STAR" custom design finish
- Agathis back & side, gloss "STAR" custom design finish
- Reversed headstock, 4 in line
- Okoume neck, gloss "STAR" custom design finish
- Matching Headstock, gloss "STAR" custom design finish
- Tecwood fretboard & bridge
- Ortega MagusUke electronics w/ tuner
- Die-cast tuning machines, black w/ black buttons
- Color matching gig bag included

THE PRIVATE ROOM

DSSUITE-UKE



DISTRESSED SATIN FINISH
CONCERT scale: 376 mm (14.80")
nut width: 35 mm (1.38")



- Solid Alaskan spruce top, satin distressed tobacco finish
- Mahogany back & side, satin distressed tobacco finish
- Reversed headstock, 4 in line
- Okoume neck, satin finish
- No body binding, walnut fretboard binding
- Tecwood fretboard & bridge
- Ortega MagusUke electronics w/ tuner
- Die-cast tuning machines black/black, chrome/black
- Deluxe gig bag included



LEFT
HANDED
available

LEFT
HANDED
available

RUMG
INCL. BAG

RUMG-CE
INCL. BAG

RUWN
INCL. BAG

RUWN-CE
INCL. BAG

RUBO
INCL. BAG

RUBO-CE
INCL. BAG

- Mango (MG) || Walnut (WN) || Bamboo (BO) top, satin open pore finish
- Mango (MG) || Walnut (WN) || Bamboo (BO) back & side, satin open pore finish
- Reversed headstock, 4 in line
- Okoume neck, satin finish
- Walnut top, bottom & fretboard binding (MG, BO)
- Maple top, bottom & fretboard binding (WN)
- Tecwood fretboard & bridge
- Ortega MagusUke electronics w/ tuner (-CE)
- Die-cast tuning machines, gold w/ black buttons
- Deluxe gig bag included



	scale	nut width
CONCERT	376 mm (14.80")	35 mm (1.38")

MG = Mango
WN = Walnut
BO = Bamboo



LEFT
HANDED
available

RUHZ-SBK

RUHZ-CE-SBK

RUHZ-MM

RUHZ-CE-MM

- Okoume (SBK) || Mahogany (MM) top, satin open pore finish
- Okoume (SBK) || Mahogany (MM) back & side, satin open pore finish
- Reversed headstock, 4 in line
- Okoume neck & headstock veneer, satin finish (SBK) || Okoume neck & Mahogany headstock veneer, satin finish (MM)
- Black ABS top, bottom & fretboard binding
- Tecwood fretboard & bridge
- Ortega MagusUke electronics w/ tuner (-CE)
- Die-cast tuning machines, black w/ black buttons

	scale	nut width
CONCERT	376 mm (14.80")	35 mm (1.38")

SBK = satin black
MM = natural mahogany



BAMBOO SERIES

ALL SOLID, SUSTAINABLE



ELECTRONICS W/ TUNER
ORTEGA
MagusUke

ECOTIP



Sustainability is always an important factor for Ortega Guitars when selecting materials for our products, and there are few natural materials suitable for instrument building that are more sustainable than bamboo. This unique material continues to grow very quickly, without replanting, and its grain pattern actually makes it stronger than many typical hardwoods.



NEW

RUNAB-SO
SOPRANO
INCL. BAG



NEW

RUNAB-CC
CONCERT
INCL. BAG



NEW

RUNAB-TE
TENOR
INCL. BAG

- Solid Bamboo top, satin finish
- Solid Bamboo back & side, satin finish
- Bamboo neck, satin finish
- Black ABS body & fretboard binding
- Bamboo fretboard & bridge
- Lasered rosette

- Ortega MagusUke electronics w/ tuner
- Graph Tech® Ratio friction tuning machines black w/ black buttons
- Deluxe gig bag included



	scale	nut width
SOPRANO	350 mm (13.78")	36 mm (1.42")
CONCERT	382 mm (15.04")	36 mm (1.42")
TENOR	432 mm (17.00")	37 mm (1.45")



NEW

RUSWB-SO
SOPRANO
INCL. BAG



NEW

RUSWB-CC
CONCERT
INCL. BAG



NEW

RUSWB-TE
TENOR
INCL. BAG

- Solid Bamboo top, satin stone washed finish
- Solid Bamboo back & side, satin stone washed finish
- Bamboo neck, satin stone washed finish
- Black ABS body & fretboard binding
- Bamboo fretboard & bridge

- Lasered rosette
- Graph Tech® Ratio friction tuning machines black w/ black buttons
- Deluxe gig bag included



	scale	nut width
SOPRANO	350 mm (13.78")	36 mm (1.42")
CONCERT	382 mm (15.04")	36 mm (1.42")
TENOR	432 mm (17.00")	37 mm (1.45")

with EQ **ELECTRONICS W/ TUNER**
ORTEGA
 MagusUke



RFU10S
SOPRANO
INCL. BAG



RFU11S
CONCERT
INCL. BAG



RFU11SE 
CONCERT
INCL. BAG

- Sapele top, satin finish
- Sapele back & side, satin finish
- Mahogany neck, satin finish
- Walnut fretboard & bridge
- Ortega MagusUke electronics w/ tuner (RFU11SE)

- Die-cast tuning machines, chrome w/ black buttons
- Deluxe gig bag included



	scale	nut width
SOPRANO	350 mm (13.78")	36 mm (1.42")
CONCERT	380 mm (14.96")	36 mm (1.42")



RFU10Z
SOPRANO
INCL. BAG



RFU10ZE 
SOPRANO
INCL. BAG



RFU11Z
CONCERT
INCL. BAG

LEFT HANDED
 available



RFU11ZE 
CONCERT
INCL. BAG

LEFT HANDED
 available

- Zebrawood top, satin finish
- Zebrawood back & side, satin finish
- Mahogany neck, satin finish
- Walnut fretboard & bridge
- Ortega MagusUke electronics w/ tuner (RFU10ZE & RFU11ZE)

- Die-cast tuning machines, chrome w/ black buttons
- Deluxe gig bag included



	scale	nut width
SOPRANO	350 mm (13.78")	36 mm (1.42")
CONCERT	380 mm (14.96")	36 mm (1.42")



TIMBER SERIES

OPEN PORE



RUEB-SO
SOPRANO
INCL. BAG



RUEB-CC
CONCERT
INCL. BAG



RUEB-TE
TENOR
INCL. BAG

- Ebony top, open pore finish
- Ebony back & side, open pore finish
- Mahogany neck, satin finish
- Ebony headstock veneer
- Tortoise style binding & tortoise style rosette

- Walnut fretboard & bridge
- Die-cast tuning machines, gold w/ black buttons
- Deluxe gig bag included



	scale	nut width
SOPRANO	350 mm (13.78")	35 mm (1.38")
CONCERT	380 mm (14.96")	36 mm (1.42")
TENOR	440 mm (17.32")	37 mm (1.45")

SOLID TOP



RUTI-SO
SOPRANO
INCL. BAG



RUTI-CC
CONCERT
INCL. BAG



RUTI-TE
TENOR
INCL. BAG

- Solid cedar top, satin finish
- Walnut back & side, satin finish
- Okoume neck, satin finish
- Walnut/maple body binding
- Walnut fretboard & bridge
- Maple "bar" fretboard inlays
- Walnut fretboard binding

- Classic headstock, Ovangkol veneer
- Bone nut & saddle
- Die-cast tuning machines, gold w/ black buttons
- Deluxe gig bag included



	scale	nut width
SOPRANO	346 mm (13.62")	35 mm (1.38")
CONCERT	382 mm (15.04")	36 mm (1.42")
TENOR	432 mm (17.00")	37 mm (1.45")

TIMBER SERIES

**SOLID TOP & BACK,
OPEN PORE FINISH**



RUACA-CC
CONCERT
INCL. BAG



RUACA-TE
TENOR
INCL. BAG



RUACA-BA
BARITONE
INCL. BAG

- Solid acacia top, open pore finish
- Solid acacia back, open pore finish
- Acacia side, open pore finish
- Okoume neck, satin finish
- Padouk top, back & fretboard binding
- Tecwood fretboard & bridge
- Die-cast tuning machines, gold w/ black buttons
- Deluxe gig bag included



	scale	nut width
CONCERT	376 mm (14.80")	35 mm (1.38")
TENOR	430 mm (16.93")	35 mm (1.38")
BARITONE	510 mm (20.08")	38 mm (1.49")

ALL SOLID MAHOGANY



RU10
SOPRANO
INCL. BAG



RU11
CONCERT
INCL. BAG

- Solid mahogany top, satin finish
- Solid mahogany back & side, satin finish
- Mahogany neck, satin finish
- Ivory ABS binding
- Walnut fretboard & bridge
- Open gear tuning machines, gold w/ white buttons
- Deluxe gig bag included



	scale	nut width
SOPRANO	350 mm (13.78")	36 mm (1.42")
CONCERT	380 mm (14.96")	36 mm (1.42")



PRISM SERIES



TENOR scale: 432 mm (17.00")
nut width: 37 mm (1.45")

RUPR-TQB



- Flamed maple top, gloss transparent tequila fade finish
- Flamed maple back & side, gloss transparent tequila fade finish
- Maple neck, gloss transparent tequila fade finish
- Maple fretboard, fretboard binding & bridge
- Slotted headstock, flamed maple veneer
- Walnut binding & Abalone style purfling & rosette, gloss transparent color fade finish
- Bone nut & saddle
- Single tuning machines, gold w/ gold buttons
- Deluxe gig bag included



TENOR scale: 432 mm (17.00")
nut width: 37 mm (1.45")

RUPR-IVY



- Flamed maple top, gloss transparent ivy fade finish
- Flamed maple back & side, gloss transparent ivy fade finish
- Maple neck, gloss transparent ivy fade finish
- Walnut fretboard, fretboard binding & bridge
- Slotted headstock, flamed maple veneer
- Walnut binding & Abalone style purfling & rosette, gloss transparent color fade finish
- Bone nut & saddle
- Single tuning machines, gold w/ gold buttons
- Deluxe gig bag included

LIZARD SERIES



CONCERT scale: 380 mm (14.96")
nut width: 36 mm (1.42")



ELECTRONICS W/ TUNER
ORTEGA
MagusUke



LIZARD-CC-GB



- Paldao top, satin finish
- Paldao back & side, satin finish
- Mahogany neck, gloss finish
- Walnut binding
- Walnut fretboard & bridge
- Maple Lizard fretboard inlay
- Ortega MagusUke electronics w/ tuner
- Die-cast tuning machines, gold w/ gold buttons
- Deluxe gig bag included



TENOR scale: 432 mm (17.00")
nut width: 37 mm (1.45")



ELECTRONICS W/ TUNER
ORTEGA
MagusUke

LIZARD-TE-GB



- Paldao top, satin finish
- Paldao back & side, satin finish
- Mahogany neck, gloss finish
- Walnut binding
- Walnut fretboard & bridge
- Maple Lizard fretboard inlay
- Ortega MagusUke electronics w/ tuner
- Die-cast tuning machines, gold w/ gold buttons
- Deluxe gig bag included

OUBJ100-SBK



scale: 394 mm (15.51")
nut width: 35 mm (1.38")



- 4string Banjo
- Hard maple neck, satin black finish
- Maple ply body, closed back, satin black finish
- Ovangkol fretboard
- 18 brackets
- Chrome hardware
- Remo ebony head, black
- Open gear tuning machines
- Deluxe Banjo bag included

BUILT-IN PASSIVE PICKUP SYSTEM
with **E** PICKUP BUILT-IN

LEFT HANDED
available

OUBJE90-MA

with **E**



scale: 394 mm (15.51")
nut width: 35 mm (1.38")



- 4string Banjo
- Hard maple neck, natural
- Maple body, open back
- Maple fretboard w/ black ABS binding
- 12 brackets, brushed brass
- Remo head, coated
- Open gear brushed brass tuning machines
- Built-in passive transducer pickup system
- Deluxe Banjo bag included





CUSTOM BUILT SERIES



**ALL SOLID MAHOGANY
DOUBLE SOUNDHOLE
BUILT-IN ARMREST
SCALLOPED CUTAWAY**

**CONCERT
4STRING**

scale: 380 mm (14.96")
nut width: 38 mm (1.49")

ECLIPSE-CC4



- Solid Mahogany top, gloss finish
- Solid Mahogany back & side, gloss finish
- Solid Okoume neck, gloss finish
- Slotted headstock
- Walnut top, back & fretboard binding
- Walnut rear headstock veneer
- Walnut fretboard & bridge
- Eclipse fretboard inlays, custom made
- Additional side soundhole
- Bone nut & saddle
- Single tuning machines, gold w/ gold buttons
- Deluxe gig bag included



**ALL SOLID MAHOGANY
DOUBLE SOUNDHOLE
BUILT-IN ARMREST
SCALLOPED CUTAWAY**

**TENOR
8STRING**

scale: 430 mm (16.93")
nut width: 38 mm (1.49")

tuning:
8string TE = Gg-Cc-EE-AA

ECLIPSE-TE8



- Solid Mahogany top, gloss finish
- Solid Mahogany back & side, gloss finish
- Solid Okoume neck, gloss finish
- Slotted headstock
- Walnut top, back & fretboard binding
- Walnut rear headstock veneer
- Walnut fretboard & bridge
- Eclipse fretboard inlays, custom made
- Additional side soundhole
- Bone nut & saddle
- 8string tuning machines w/ tortoise style buttons
- Deluxe gig bag included



ARCHED

CONCERT

scale: 382 mm (15.04")
nut width: 37 mm (1.46")



ELECTRONICS W/ TUNER
ORTEGA
MagusUke

RUSL-HSB



- Flamed maple, arched top, satin finish
- Flamed maple arched back & side, satin finish
- Okoume neck, satin finish
- Walnut fretboard & Mandolin bridge
- Walnut fretboard binding
- Classic headstock, Ovangkol veneer
- F-holes
- Bone nut & saddle
- Die-cast tuning machines, gold w/ black buttons
- Ortega MagusUke electronics w/ tuner
- Ortega Guitars UWNY-4-CC strings
- Deluxe gig bag included





DOUBLE NECK UKULELE 4STRING, UKEBASS/4STRING, TENOR

Ukebass
scale: 510 mm (20.08")
nut width: 45 mm (1.77")

Tenor Ukulele
scale: 432 mm (17.00")
nut width: 37 mm (1.45")

tuning:
BS = E-A-D-G
TE = G-C-E-A



HYDRA-BSTE

- Dao top, satin open pore finish
- Dao back & side, satin open pore finish
- Mahogany necks, satin finish
- Ukebass 4string & Tenor 4string
- Walnut fretboard & bridge
- Walnut/ABS body binding
- Bone nut & saddle
- Custom built electronics with 3way toggle switch (Ukebass/both/Tenor)
- 4string Ukebass tuning machines black/black & 4string Ukulele single tuning machines black/black
- Deluxe gig bag included



DOUBLE NECK UKULELE 4/8STRING, TENOR

both necks
scale: 430 mm (16.93")
nut width: 38 mm (1.49")

tuning:
8string TE = Gg-Cc-EE-AA
TE = G-C-E-A



HYDRA

- Ovangkol top, satin open pore finish
- Ovangkol back & side, satin open pore finish
- Mahogany necks, satin finish
- Tenor 8string & Tenor 4string
- Slotted headstocks
- Walnut armrest & fretboard binding
- Walnut fretboard & bridge
- Tortoise style body binding
- Bone nut & saddle
- Custom built electronics with 3way toggle switch (neck 8/both/neck 4)
- 8string tuning machines gold/gold & single tuning machines gold/gold (4string)
- Deluxe gig bag included



DOUBLE NECK UKULELE 4/8STRING, TENOR

both necks
scale: 430 mm (16.93")
nut width: 38 mm (1.49")

tuning:
8string TE = Gg-Cc-EE-AA
TE = G-C-E-A



HYDRA-ZS

- Zircote top, satin open pore finish
- Zircote back & side, satin open pore finish
- Mahogany necks, satin finish
- Tenor 8string & Tenor 4string
- Slotted headstocks
- Walnut armrest
- Maple fretboards & bridges
- Mahogany body & fretboard binding
- Walnut "tree of life" fretboard inlay
- Bone nut & saddle
- Custom built electronics with 3way toggle switch (neck 8/both/neck 4)
- 8string tuning machines gold/gold & single tuning machines gold/gold (4string)
- Deluxe gig bag included



UKEBASSES

OPTIONS

SCALES & SIZES

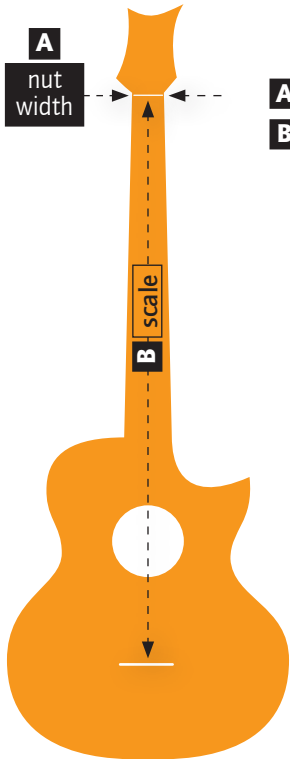

LIZZY-PRO	
A	45 mm (1.75")
B	625 mm (24.60")
RUxxx	
	45 mm (1.75")
	530 mm (20.88")
LIZZY	
	45 mm (1.75")
	513 mm (20.19")
LIZARD	
	45 mm (1.75")
	513 mm (20.19")
CAIMAN	
	45 mm (1.75")
	513 mm (20.19")

BODY

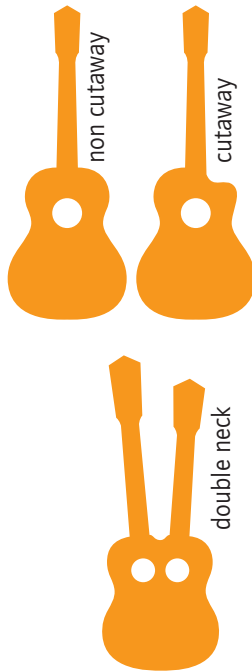

FEATURES



2way truss rod

ELECTRONICS

ORTEGA®
MagusUkePro

ORTEGA®
MagusUkebass

Electronics w/ tuner
(see page 109)

INCL. DELUXE GIG BAG
(for selected models)



BAMBOO SERIES

ALL SOLID, SUSTAINABLE

NEW

RUNAB-UB



UKEBASS

scale: 530 mm (20.88")
nut width: 45 mm (1.75")

ELECTRONICS W/ TUNER
ORTEGA®
MagusUkePro



- Solid Bamboo top, satin finish
- Solid Bamboo back & side, satin finish
- Bamboo neck, satin natural finish
- Bamboo fretboard & bridge
- Black ABS body & fretboard binding
- F-hole w/ black ABS soundhole binding
- Ortega MagusUkePro electronics w/ tuner
- Deluxe gig bag included



UKEBASS

scale: 530 mm (20.88")
nut width: 45 mm (1.75")

ELECTRONICS W/ TUNER
ORTEGA®
MagusUkePro

NEW

RUSWB-UB



- Solid Bamboo top, satin stone washed finish
- Solid Bamboo back & side, satin stone washed finish
- Bamboo neck, satin stone washed finish
- Bamboo fretboard & bridge
- Black ABS body & fretboard binding
- F-hole w/ black ABS soundhole binding
- Ortega MagusUkePro electronics w/ tuner
- Deluxe gig bag included

LIZARD SERIES



UKEBASS

with EQ ELECTRONICS W/ TUNER
ORTEGA
MagusUkeBass

scale: 513 mm (20.19")
nut width: 45 mm (1.75")

LIZZY-BSFL-GB **with EQ**
LINED FRETLESS



- Mahogany top, satin finish
- Mahogany back & side, satin finish
- Mahogany neck, satin finish
- Walnut fretboard & bridge
- Black ABS binding/ white purfling
- Lasered Lizard rosette
- Ortega MagusUkeBass electronics w/ tuner
- 15 lined frets
- 2way truss rod
- Deluxe gig bag included



LONGSCALE UKEBASS

with EQ ELECTRONICS W/ TUNER
ORTEGA
MagusUkeBass

scale: 625 mm (24.60")
nut width: 45 mm (1.75")

LIZZY-PRO **with EQ**



- Solid mahogany top, satin finish
- Mahogany back & side, satin finish
- Mahogany neck, satin finish
- Pao Ferro fretboard & bridge
- Black ABS binding/ white purfling
- Lasered Lizard rosette
- Ortega MagusUkeBass electronics w/ tuner
- 2way truss rod
- Deluxe gig bag included



UKEBASS ARCHED BACK

with EQ ELECTRONICS W/ TUNER
ORTEGA
MagusUkeBass

scale: 513 mm (20.19")
nut width: 45 mm (1.75")

CAIMAN-BS-GB **with EQ**

CAIMAN-FL-GB **with EQ**
LINED FRETLESS



- Acacia top, gloss finish
- Acacia back (arched) & side, gloss finish
- Mahogany neck, gloss finish
- Walnut fretboard & bridge
- Mahogany body & fretboard binding
- Abalone style purfling
- Mahogany dot fretboard inlays
- Ortega MagusUkeBass electronics w/ tuner
- 2way truss rod
- Deluxe gig bag included

CUSTOM BUILT SERIES



UKEBASS
scale: 513 mm (20.19")
nut width: 45 mm (1.75")

TENOR UKULELE
scale: 432 mm (17.00")
nut width: 37 mm (1.45")

with EQ CUSTOM BUILT ELECTRONICS
ORTEGA
MagusUke

HYDRA-BSTE **with EQ**

UKEBASS 4STRING, TENOR DOUBLE NECK UKULELE 4STRING

tuning:
BS = E-A-D-G
TE = G-C-E-A



- Dao top, satin open pore finish
- Dao back & side, satin open pore finish
- Mahogany necks, satin natural finish
- Ukebass 4string & Tenor 4string
- Walnut fretboard & bridge
- Walnut/ABS body binding
- Bone nut & saddle
- Custom built electronics with 3way toggle switch (Ukebass/both/Tenor)
- 4string Ukebass tuning machines black/black & 4string Ukulele single tuning machines black/black
- Deluxe gig bag included

INDEX

Keiki® UKULELES	50
K1 Series	51
K2 Series	51
K3 Series	53
Keiki® ACCESSORIES	54
Picks	54
Straps	55
Ukulele Bags	55

Keiki® UKULELES

BY ORTEGA®

ALL K2 & K3 UKULELE PACKS INCLUDES:

- Keiki® K2 or K3 Ukulele
- Keiki® Headstock tuner
- Keiki® Soundhole hook strap/support
- Keiki® 5 medium picks
- Keiki® Drawstring bag



OPTIONS

scales & sizes

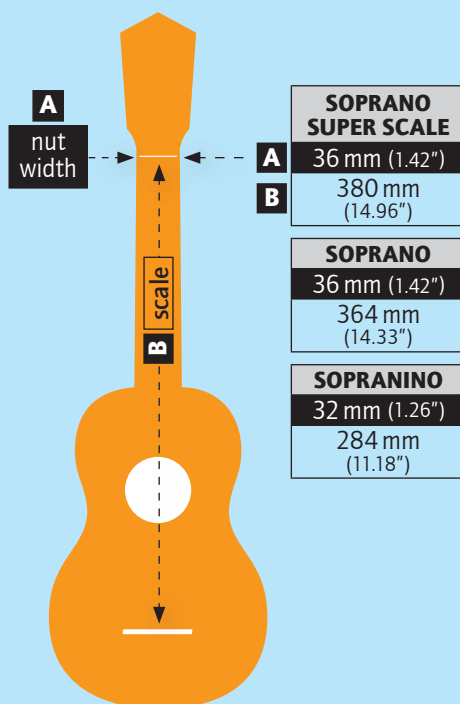

K1 SERIES

SOPRANINO

scale
284 mm (11.18")

nut width
32 mm (1.26")



K1-BL
SOPRANINO



K1-RD



K1-CO



K1-MM



K1-PNK

- Laser engraved sea turtle
- Okoume top satin, open pore
- Okoume back & side, satin open pore
- Keiki[®] headstock design w/ lasered logo
- Okoume neck & headstock veneer, satin finish
- Walnut fretboard & bridge
- Open gear tuning machines chrome w/ black buttons

- Available colors:
BL - ocean blue
RD - fire red
CO - coal
MM - natural mahogany
PNK - pink

K2 SERIES

UKULELE PACK

SUPER SCALE SOPRANO BODY, CONCERT SCALE

SOPRANO SUPER SCALE

scale
380 (14.96")

nut width
36 mm (1.42")



K2SS-BKC
SOPRANO SUPER SCALE / PACK



K2SS-OKC
PACK



K2SS-RKC
PACK



- Agathis top, custom designed, satin finish
- ABS body, slightly arched
- Matching headstock veneer
- Okoume neck, satin finish
- ABS fretboard & bridge
- Open gear tuning machines chrome w/ black buttons

- Headstock tuner, soundhole hook strap/support, 5 medium picks and drawstring bag included!
- Available designs:
BKC - blue kaleidoscope
OKC - orange kaleidoscope
RKC - red kaleidoscope

K2 SERIES

UKULELE PACK



UKULELE
PACK

SOPRANO

scale
364 mm (14.33")

nut width
36 mm (1.42")



K2-LGR
SOPRANO / PACK

NEW

NEW

NEW

NEW

NEW



K2-LAF
PACK

K2-CBM
PACK

K2-FYD
PACK

K2-TMO
PACK

K2-SCL
PACK

- Agathis top, satin finish
- ABS body, slightly arched
- Matching headstock veneer
- Okoume neck, satin finish
- ABS fretboard & bridge
- Open gear tuning machines chrome w/ black buttons

- Headstock tuner, soundhole hook strap/support, 5 medium picks and drawstring bag included!
- Available designs:
LGR - lemon grass
LAF - lavender field
CBM - caribbean mint
FYD - fairy dust
TMO - tomatillo
SCL - silent clouds

K2 SERIES

UKULELE PACK



UKULELE
PACK

LEFT
HANDED
available



K2-68
SOPRANO / PACK



K2-SP
PACK

K2-EM
PACK

K2-TM
PACK

K2-SR
PACK

K2-VP
PACK

- Agathis top, custom designed
- ABS body, slightly arched
- Keiki® headstock design w/ custom designed veneer
- Okoume neck, satin finish
- ABS fretboard & bridge
- Open gear tuning machines chrome w/ black buttons

- Headstock tuner, soundhole hook strap/support, 5 medium picks and drawstring bag included!
- Available designs:
68 - peace '68
SP - spaceman
EM - el muerto
TM - totem
SR - samurai
VP - voodoo puppet

SOPRANO

scale
364 mm (14.33")

nut width
36 mm (1.42")

K2 SERIES

UKULELE PACK



SOPRANO

scale
364 mm (14.33")

nut width
36 mm (1.42")

K2-MAH
SOPRANO / PACK



K2-MAP
PACK



- Mahogany (MAH) || Maple (MAP) top, satin finish
- ABS body, slightly arched
- Keiki® headstock design w/ custom designed veneer
- Okoume neck, satin finish
- ABS fretboard & bridge
- Open gear tuning machines chrome w/ black buttons

- Headstock tuner, soundhole hook strap/support, 5 medium picks and drawstring bag included!
- Available designs:
MAH - mahogany
MAP - maple

K3 SERIES

UKULELE PACK



SOPRANO

scale
364 mm (14.33")

nut width
36 mm (1.42")

K3-ACA
SOPRANO / PACK



K3-SPM
PACK



K3-WEB
PACK



- Acacia (ACA) || Spalted Maple (SPM) || White Ebony (WEB) top, satin finish
- ABS body, slightly arched
- Okoume neck, satin finish
- ABS fretboard & bridge
- Open gear tuning machines chrome w/ black buttons

- Headstock tuner, soundhole hook strap/support, 5 medium picks and drawstring bag included!
- Available designs:
ACA - acacia
SPM - spalted maple
WEB - white ebony

PICKS



KPSP-5



KPEM-5



KP68-5



KPTM-5



KPSR-5



KPVP-5



KEIKI® DESIGNER PICKS

5 PICKS – 5 DIFFERENT DESIGNS

Keiki® designer picks are made of high quality celluloid, medium 0.71 mm, with a glossy surface.

- KPSP-5** spaceman
- KPEM-5** el muerto
- KP68-5** peace '68
- KPTM-5** totem
- KPSR-5** samurai
- KPVP-5** voodoo puppet

(5 slightly different designs in each series)

DISPLAY WITH 150 PICKS

Attractive, 100% recyclable hard paper sales display with 150x Keiki® designer picks included.

- KPSD-150** 25x KPSP-5 spaceman
 - 25x KPEM-5 el muerto
 - 25x KP68-5 peace '68
 - 25x KPTM-5 totem
 - 25x KPSR-5 samurai
 - 25x KPVP-5 voodoo puppet
- (5x5 slightly different designs in each series)

REFILL PACKS

Perfect to refill the KPSD-150 sales box or have safety stock in your pocket and for your fans. Each refill pack contains 25 picks (5x5 slightly different designs).

- KPSP-25RF** spaceman
- KPEM-25RF** el muerto
- KP68-25RF** peace '68
- KPTM-25RF** totem
- KPSR-25RF** samurai
- KPVP-25RF** voodoo puppet

KPSD-150

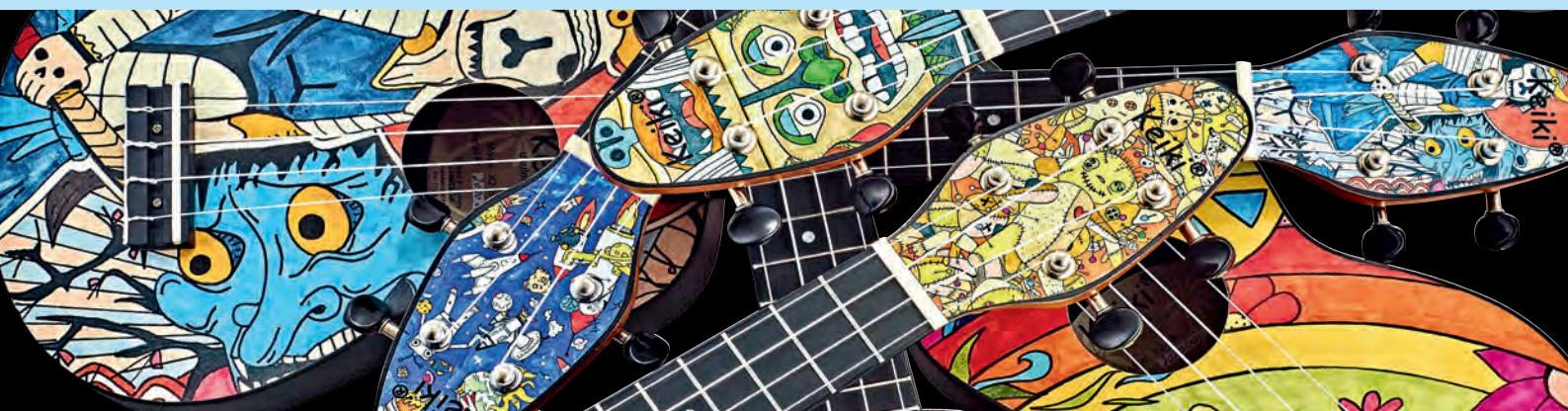

STRAPS

KEIKI® DESIGNER UKULELE & GUITAR STRAPS

Made from strong but soft nylon and equipped with suede leather ends.
 Sizes: Ukulele 36 mm (1.42") width, up to 1440 mm (56.70") length / Guitar 50 mm (1.97") width, up to 1580 mm (62.20") length. Embossed logo on genuine leather badge.



UKULELES

KNS-SP-U
spaceman

KNS-EM-U
el muerto

KNS-68-U
peace '68

KNS-TM-U
totem

KNS-SR-U
samurai

KNS-VP-U
voodoo puppet



GUITARS

KNS-SP
spaceman

KNS-EM
el muerto

KNS-68
peace '68

KNS-TM
totem

KNS-SR
samurai

KNS-VP
voodoo puppet

UKULELE BAGS

KEIKI® DESIGNER UKULELE BAGS

Professional ukulele bags – designed to be different and priced for any budget. Made from sturdy nylon material with a 10 mm soft inside padding. Includes an accessory compartment (fits an ORTEGA OPUSxx portable uke stand) and two adjustable shoulder straps.

- KUB-SP-xx** spaceman
- KUB-EM-xx** el muerto
- KUB-68-xx** peace '68
- KUB-TM-xx** totem
- KUB-SR-xx** samurai
- KUB-VP-xx** voodoo puppet

Sizes: soprano (SO) – concert (CC) – tenor (TE)



SPACEMAN

EL MUERTO

PEACE '68



TOTEM

SAMURAI

VOODOO PUPPET



DIMENSIONS	
	A (inside)
soprano length	55.0 cm 21.65"
concert length	62.0 cm 24.41"
tenor length	68.0 cm 26.77"



ACOUSTIC BASSES

OPTIONS

SCALES & SIZES

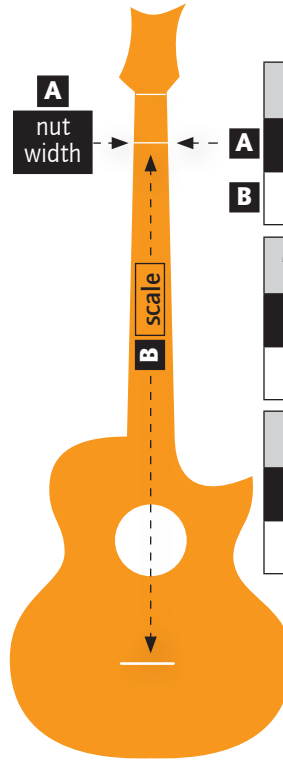

LONG SCALE
45 mm (1.77")
863 mm (34")

MEDIUM SCALE
45 mm (1.77")
812 mm (32")

SHORT SCALE
44 mm (1.73")
625 mm (24.60")

BODY

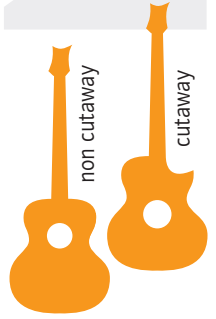

FEATURES



2way truss rod

INCL. DELUXE GIG BAG
(for selected models)



BLACK TOP

NEW

medium scale: 812 mm (32")
nut width: 45 mm (1.77")
body depth: 115 mm (4.52")

4STRING

D8CE-4



- Spruce top, gloss black finish
- Mahogany back & side, gloss finish
- Mahogany neck, gloss finish
- White ABS fretboard & body binding, pinstripe purfling
- Walnut fretboard & bridge w/ dot inlays
- Gold hardware
- ORTEGA MagusPRO/B electronics w/ tuner
- 2way truss rod



ELECTRONICS W/ TUNER
ORTEGA
MagusPRO/B





NEW

D7E-4 

medium scale: 812 mm (32")
nut width: 45 mm (1.77")
body depth: 115 mm (4.52")

4STRING

- Spruce top, satin finish
- Mahogany back & side, satin finish
- Mahogany neck, satin finish
- White ABS fretboard & body binding, pinstripe purfling
- Walnut fretboard & bridge w/ dot inlays
- Chrome hardware
- ORTEGA MagusPRO/B electronics w/ tuner
- 2way truss rod



NEW

D7CE-4 

CUTAWAY

 **ELECTRONICS W/ TUNER**
ORTEGA
MagusPRO/B



NEW

D7E-BFT-4 

medium scale: 812 mm (32")
nut width: 45 mm (1.77")
body depth: 115 mm (4.52")

4STRING

- Spruce top, satin bourbon burst finish
- Mahogany back & side, satin finish
- Mahogany neck, satin finish
- Black ABS fretboard & body binding, pinstripe purfling
- Walnut fretboard & bridge w/ dot inlays
- Chrome hardware
- ORTEGA MagusPRO/B electronics w/ tuner
- 2way truss rod



NEW

D7CE-BFT-4 

CUTAWAY

 **ELECTRONICS W/ TUNER**
ORTEGA
MagusPRO/B



NEW

D7E-SBK-4 

medium scale: 812 mm (32")
nut width: 45 mm (1.77")
body depth: 115 mm (4.52")

4STRING

- Spruce top, satin black finish
- Mahogany back & side, satin black finish
- Mahogany neck, satin black finish
- White ABS fretboard & body binding, pinstripe purfling
- Walnut fretboard & bridge w/ dot inlays
- Chrome hardware
- ORTEGA MagusPRO/B electronics w/ tuner
- 2way truss rod



NEW

D7CE-SBK-4 

CUTAWAY

 **ELECTRONICS W/ TUNER**
ORTEGA
MagusPRO/B



DEEP SERIES



D538-4



SOLID SPRUCE

medium scale: 812 mm (32")
nut width: 45 mm (1.77")
body depth: 122 mm (4.80")

4STRING



ELECTRONICS W/ TUNER
ORTEGA
MagusPRO/B

- Solid Alaskan spruce top, satin finish
- Sapele back & side, open pore finish
- Mahogany neck, open pore finish
- Pao Ferro fretboard w/ black ABS binding
- Pao Ferro bridge
- Black ABS binding/bk-wh-bk purfling
- Chrome hardware
- ORTEGA MagusPRO/B electronics w/ tuner
- 2way truss rod



SOLID SPRUCE

medium scale: 812 mm (32")
nut width: 45 mm (1.77")
body depth: 122 mm (4.80")

4STRING



ELECTRONICS W/ TUNER
ORTEGA
MagusPRO/B

D558-4



- Solid Alaskan spruce top, satin finish
- Walnut back & side, open pore finish
- Mahogany neck, open pore finish
- Pao Ferro fretboard w/ black ABS binding
- Pao Ferro bridge
- Ivory ABS binding/ bk-wh-bk purfling
- Gold hardware
- ORTEGA MagusPRO/B electronics w/ tuner
- 2way truss rod

THE PRIVATE ROOM

STRIPESU.ACB



BUILT-IN ARMREST
AAA STRIPED EBONY
BACK & SIDE

medium scale: 812 mm (32")
nut width: 45 mm (1.77")
body depth: 122 mm (4.80")

4STRING



ELECTRONICS W/ TUNER
ORTEGA
MagusPRO/B



- 4string acoustic bass
- Solid Alaskan spruce top, gloss finish
- AAA striped ebony back & side, gloss finish
- Acacia top & bottom binding/white purfling
- Mahogany neck, gloss finish
- Medium scale
- Tecwood fretboard w/ walnut binding
- Tecwood bridge
- 2way truss rod
- Ortega signature walnut/maple/white pearl rosette
- Ortega die-cast tuning machines, gold
- Ortega MagusPro electronics w/ tuner
- Deluxe gig bag included



photo: Hendrik Holnäck



Signature SERIES

Ken Taylor
Signature models/custom made

KT-WALKER-V2



4STRING

SHORT SCALE

short scale: 625 mm (24.60")
nut width: 44 mm (1.73")
body depth: 88 mm (3.46")



Electronics w/ tuner



- Solid spruce top, satin distressed tobacco burst - open pore finish
- Flamed mahogany back & side, satin distressed tobacco burst - open pore finish
- Thinline body depth (88 mm)
- Mahogany neck, satin distressed tobacco burst
- Pao Ferro fretboard & bridge
- 19 frets
- Custom designed fretboard MOP inlays "Roman Numerals"
- Custom designed & aged Ortega D-Walker tuning machines
- Fishman PRESYS+ electronics w/ Jack & XLR output w/ tuner
- 2way truss rod
- Ortega ODW-4 balanced tension bass strings
- Deluxe gig bag included

KTSM-5



5STRING

LONG SCALE

long scale: 863 mm (34")
nut width: 45 mm (1.77")
body depth: 126 mm (4.96")



Electronics w/ tuner



- Solid North American spruce top, gloss finish
- Flamed mahogany back & side, gloss finish
- Mahogany neck, gloss finish
- Acacia fretboard & bridge
- Custom designed "Roman Numerals" fretboard inlays
- Walnut binding/white purfling
- Black hardware
- Fishman Presys+ electronics w/ tuner
- 2way truss rod
- Deluxe gig bag & straplocks included





MANDOLINS & BANJOS



photo: Maria Athens

MANDOLINS



scale: 345 mm (13.58")
nut width: 28 mm (1.10")

NA
(natural)

RMA5NA

- Mahogany top, open pore satin finish
- Mahogany back (arched) & side, open pore satin finish
- Mahogany neck, satin finish
- Ovangkol fretboard & bridge
- 2way truss rod
- 20 frets



scale: 345 mm (13.58")
nut width: 28 mm (1.10")

VS
(vintage sunburst)

RMA5VS

- Mahogany top, open pore vintage sunburst satin finish
- Mahogany back (arched) & side, open pore vintage sunburst satin finish
- Mahogany neck, satin finish
- Ovangkol fretboard & bridge
- 2way truss rod
- 20 frets

LEFT
HANDED
available



scale: 345 mm (13.58")
nut width: 28 mm (1.10")

SBK
(satin black)



**BUILT-IN PASSIVE
PICKUP SYSTEM**
PICKUP
BUILT-IN

RMAE40SBK



- Spruce top, satin black finish
- Maple back (arched) & side, satin black finish
- Maple neck, satin black finish
- Rosewood fretboard & bridge
- 2way truss rod
- 20 frets
- Piezo bridge with tone & volume control, passive
- Deluxe gig bag included



scale: 345 mm (13.58")
nut width: 28 mm (1.10")

SBK
(satin black)



**BUILT-IN PASSIVE
PICKUP SYSTEM**
PICKUP
BUILT-IN

RMFE40SBK



- Spruce top, satin black finish
- Maple back (arched) & side, satin black finish
- Maple neck, satin black finish
- Rosewood fretboard & bridge
- 2way truss rod
- 24 frets
- Piezo bridge with tone & volume control, passive
- Deluxe gig bag included



scale: 345 mm (13.58")
nut width: 28 mm (1.10")

TS
(tobacco sunburst)



ELECTRONICS W/ TUNER
ORTEGA

RMFE90TS



- Solid spruce top, gloss tobacco sunburst finish
- Maple back (arched) & side, gloss tobacco sunburst finish
- Maple neck, gloss tobacco sunburst finish
- Rosewood fretboard & ebony bridge
- Ortega SIT electronics w/ tuner
- 2way truss rod
- 24 frets
- One piece die-cast tailpiece, gold
- Deluxe gig bag included



scale: 345 mm (13.58")
nut width: 28 mm (1.10")

AVO
(antique violin oil)



ELECTRONICS W/ TUNER
ORTEGA

RMFE100AVO



- Solid distressed spruce top, antique violin oil finish
- Solid flamed maple back (arched) & side, distressed antique violin oil finish
- Maple neck, gloss tobacco sunburst finish
- Ebony fretboard & ebony bridge
- Ortega SIT electronics w/ tuner
- 2way truss rod
- 24 frets
- One piece die-cast tailpiece, gold
- Grover tuning machines
- Deluxe gig bag included



BANJOS – FALCON SERIES



BUILT-IN PASSIVE PICKUP SYSTEM
PICKUP BUILT-IN



OBJE400TBL
INCL. BAG



OBJE400TCO
INCL. BAG



LEFT
HANDED
available



OBJE400TFR
INCL. BAG



OBJE400TGR
INCL. BAG



- Quilted maple resonator, semi-gloss finish
- Maple ply rim, semi-gloss finish
- Hard maple neck, maple fingerboard
- Brass tone ring, 24 brackets
- Brushed nickel hardware
- Die-cast machine head

- Built-in passive pickup system w/ volume control
- Remo head, fiberskin style
- Deluxe gig bag included



TBL = transparent blue
TCO = transparent charcoal
TFR = transparent fire red
TGR = transparent green



OBJ550W-SNT



SATIN FINISH



- 5string Banjo
- Walnut neck
- Burl walnut resonator
- Rosewood fretboard
- Walnut ply rim
- Chrome armrest, Ortega engraved
- 24 brackets
- Flat flange
- Chrome hardware
- Remo head, renaissance
- Rolled brass tone ring
- Geared machine head
- Deluxe Banjo bag included

OBJ750-MA



- 5string Banjo
- Hard maple neck
- Flamed maple resonator
- Rosewood fretboard
- 3ply solid maple rim
- Chrome armrest, Ortega engraved
- 24 brackets
- One piece flange
- Chrome hardware
- Remo head, coated
- Brass tone ring
- Geared machine head
- Natural gloss on maple
- Deluxe Banjo bag included

OBJ850-MA



ELABORATELY CARVED HEEL AND HEADSTOCK



- 5string Banjo
- Hard maple neck
- Flamed maple resonator
- Rosewood fretboard
- 3ply solid maple rim
- Golden armrest, Ortega engraved
- 24 brackets
- One piece flange
- Golden hardware
- Remo head, Weatherking clear
- Brass tone ring
- Geared machine head
- Gloss on flamed maple
- Deluxe Banjo bag included

OBJ950-FMA



ALL FLAMED MAPLE



- 5string Banjo
- Flamed maple neck
- Flamed maple resonator
- Ebony fretboard
- 3ply solid maple rim
- Golden armrest, Ortega engraved
- 24 brackets
- One piece flange
- Golden hardware
- Remo head, coated
- Bell brass tone ring
- Geared machine head
- Gloss on all flamed maple
- Deluxe Banjo bag included



BANJOS – RAVEN SERIES

OBJ250-SBK

5STRING BANJO



- Mahogany neck & resonator
- Ovangkol fretboard
- Mahogany ply rim
- 24 brackets, chrome hardware
- Remo ebony head, black
- Die-cast machine head
- Deluxe Banjo bag included

OBJE250OP-SBK



**5STRING BANJO
OPEN BACK**



**BUILT-IN PASSIVE
PICKUP SYSTEM
PICKUP
BUILT-IN**



- Mahogany neck
- Ovangkol fretboard
- Mahogany ply rim
- 24 brackets, chrome hardware
- Remo ebony head, black
- Die-cast machine head
- Built-in passive pickup system w/
volume control
- Deluxe Banjo bag included

OBJ350/6-SBK

6STRING GUITAR BANJO



- Mahogany neck & resonator
- Ovangkol fretboard
- Aluminum rim
- Chrome armrest, Ortega engraved
- 30 brackets, chrome hardware
- Remo ebony head, black
- Die-cast machine head
- Deluxe Banjo bag included



BANJOS – RAVEN SERIES



6STRING GUITAR BANJO

LEFT
HANDED
available

with
E
BUILT-IN PASSIVE
PICKUP SYSTEM
PICKUP
BUILT-IN

OBJE350/6-SBK with
E



- Mahogany neck & resonator
- Ovangkol fretboard
- Aluminum rim
- Chrome armrest, Ortega engraved
- 30 brackets, chrome hardware
- Remo ebony head, black
- Die-cast machine head
- Built-in passive pickup system w/ volume control
- Deluxe Banjo bag included



5STRING BANJO

OBJ450-SBK



- Mahogany neck & resonator
- Rosewood fretboard
- Mahogany ply rim
- 24 brackets, chrome hardware
- Remo ebony head, black
- Rolled brass tone ring
- Geared machine head
- Deluxe Banjo bag included



5STRING BANJO

OBJ650-SBK



- Mahogany neck & resonator
- Rosewood fretboard
- 3ply solid maple rim
- Chrome armrest, Ortega engraved
- 24 brackets, chrome hardware
- One piece flange
- Remo ebony head, black
- Zinc alloy tone ring
- Die-cast machine head
- Deluxe Banjo bag included





AMPLIFICATION SERIES



ORTEGA ACOUSTIC AMPLIFICATION

Following the success of the first-ever acoustic amplifier stack, the COne provides acoustic musicians multiple functionalities in a convenient package. The COne is ideal for both performing and practice, featuring 100 watts of power, a built-in DSP effects unit, and two separate channels. Thanks to the integrated pole mount, it can even be utilized as a compact PA for your next gig. The amplifier combo comes with two wood options: a light Ash or a dark and elegant Walnut housing.

AMPLIFIER COMBO

NEW

CONE-ASH

- 100 Watt RMS
- 5 ply Ash cabinet
- Built-in pole mount
- 1/4" and 1/4"/XLR combination inputs
- 2x channels
- Built-in DSP reverb & chorus
- Effects loop
- Headphone & speaker out
- PRE/POST EQ D.I. out
- 6.5" speaker and additional 3" tweeter
- Dust cover included

NEW

CONE-ASH-US

- AC 120V, 50-60 Hz version

NEW

CONE-WND

- 100 Watt RMS
- 5 ply Ash (Walnut finish) cabinet
- 1/4" and 1/4"/XLR combination inputs
- 2x channels
- Built-in DSP reverb & chorus
- Effects loop
- Headphone & speaker out
- PRE/POST EQ D.I. out
- 6.5" speaker and additional 3" tweeter
- Dust cover included

NEW

CONE-WND-US

- AC 120V, 50-60 Hz version

CONE-ASH

Cone



INCL. DUST COVER



CONE-WND



Top panel

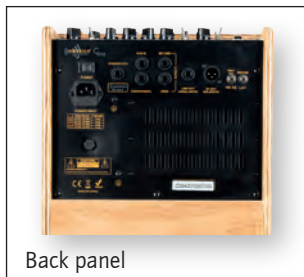

Back panel

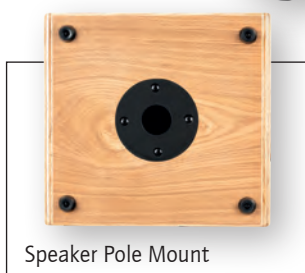

Speaker Pole Mount

ORTEGA ACOUSTIC AMPLIFICATION – THE FIRST ACOUSTIC AMP HEAD

With the introduction of the first acoustic amplification head, Ortega sets a milestone in flexibility and sound. Featuring true 100 Watt power and two channels in combination with the latest SMT & DSP technology, the H one delivers what acoustic players have been searching for. With a satin-finished solid Ash housing, the H one head looks as good as it sounds.



Hone
HONE



INCL. BAG

AMPLIFIER

HONE

- 100 Watt RMS
- 7 ply Ash cabinet
- 1/4" and 1/4"/XLR combination inputs
- 2x channels
- Built-in DSP reverb & chorus
- Effect send/return
- Headphone out
- PRE/POST EQ D.I. out
- Speaker A/B out
- Carry bag included

NEW

HONE-US

- AC 120V, 50-60 Hz version

The ORTEGA acoustic amplification SONE and STWO speaker cabinets are the perfect complement to the HONE 100 Watt amplifier head. Each cabinet features a satin finished solid Ash housing, tour-grade spring loaded handles and a speaker pole mount for exceptional convenience and durability. Use separately, or in combination for the ultimate in flexible performance.



SONE

Sone

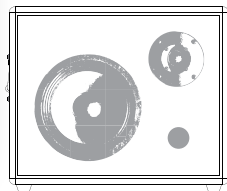

6.5" speaker and additional 3" tweeter inside



INCL. BAG

SPEAKER CABINET

SONE

- 150 Watt / 4 Ohm
- 7 ply Ash cabinet
- 40 HZ - 20 kHz frequency range
- 6.5" speaker and additional 3" tweeter
- Carry bag included

STWO

- 150 Watt / 4 Ohm
- 7 ply Ash cabinet
- 40 HZ - 20 kHz frequency range
- 8" speaker
- Carry bag included



STWO

STWO

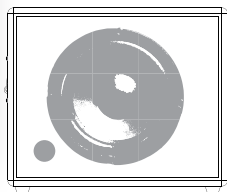

8" speaker inside



Speaker Pole Mount



Closed back

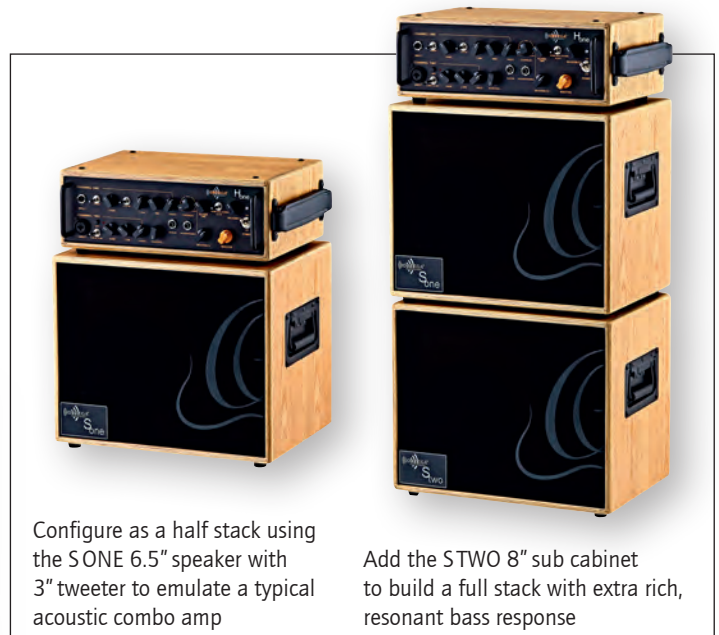

Configure as a half stack using the SONE 6.5" speaker with 3" tweeter to emulate a typical acoustic combo amp

Add the STWO 8" sub cabinet to build a full stack with extra rich, resonant bass response



STOMP BOX EFFECT SERIES

ORTEGA QUANTUMloop - DIGITAL MULTI PERCUSSION STOMP BOX & LOOPER

Choose between 16 DIFFERENT BUILT-IN DRUM & PERCUSSION SAMPLED SOUNDS...

... PLUS ADD 4 CUSTOM SAMPLES (2 PER BANK) VIA USB.

20 AVAILABLE SAMPLED SOUNDS!

FREE ONLINE DOWNLOAD for sound import software (Mac & Windows)

BANK A		BANK B	
DRY KICK DRUM	SLAP CAJON	BALLAD SNARE	FINGER SNIP
FAT KICK DRUM	DOUMBK SLAP	SOUL SNARE	SHORT SHAKE
SWEET KICK DRUM	COWBELL	THE RIM	TAMBOURINE
80'S ELECTRO	PERSONAL 1	FOOT HIHAT	PERSONAL 1
DEEP CAJON	PERSONAL 2	THE CLAP	PERSONAL 2



For informational video scan QR Code



CHANGE BETWEEN SOUNDS ON THE FLY. WITH 20 SAMPLES AND A LOOPER, YOUR POSSIBILITIES ARE ENDLESS.



QUANTUMexp

For maximum performance add the QUANTUMexp to your setup. Once connected with the QUANTUMloop via "trigger input" the sounds of BANK B are under the control of QUANTUMexp.

The QUANTUMexp operates "active" and includes a 9V battery.



QUANTUMloop

BUILT-IN LOOPER for instrument & sound banks

DIGITAL STOMP BOX & LOOPER with 16 built-in drum & percussion samples!

- 16 pre-installed sounds
- 4 empty slots for custom samples
- Built-in looper with unlimited numbers of overdubs
- Loop length: Up to 5 minutes
- Software for uploads & erase (free online download) - Mac & Windows
- Comfortable ergonomic design
- Solid mahogany wood housing
- Non-slip bottom coating & foot rest
- IN & OUT 6.3 mm (1/4") jack - True Bypass



- Removable foot rest (hook & loop)



- Trigger input, instrument in and sweeping looper volume control



- Sweeping volume control, Dynamic (velocity sensitivity) ON/OFF, instrument out (a true discrete pass-through) & USB port for sound import



FREE POWER SUPPLY included!

- FREE 9V certified quality power supply included (QUANTUMloop)

ORTEGA DIGITAL STOMP BOXES - PERFECT FOR SINGER/SONGWRITERS ON THE GO OR IN THE STUDIO

The Ortega **HORSE KICK PRO** digital stomp box is a great tool for guitarists, singers, songwriters and street performers wanting to add a percussive element to any performance. With digital samples of real percussion sounds the HORSE KICK PRO Stomp Box is way ahead of any existing analog/acoustic stomp boxes currently on the market. Just connect your favorite HORSE KICK PRO to any amplifier or sound system and enhance your solo performance.

HORSEKICKPRO

DIGITAL STOMP BOX with multiple built-in digital samples of percussion sounds that can be played on its own, as a percussive instrument, or blended with your stringed instrument signal through the output.

- Digital samples of percussion instruments – just choose between 5 different percussion samples and tap your foot
- Comfortable ergonomic design for foot tapping
- Solid sapele (mahogany) wood housing
- Non-slip bottom coating
- Velocity sensitive for an expressive experience
- Sweeping volume control to adjust percussion sounds (blend the percussion sound with the unaffected instrument signal together through the output to one channel)
- 6.3 mm (1/4") input & output jack
- Powered 9V battery or power supply included

HORSEKICKPRO-UK

- AC 220/240V, 50 Hz UK version

NEW



Your **HANDS FREE** rhythm section

Choose between **5 DIFFERENT PERCUSSION SAMPLES:**

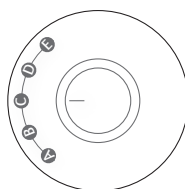

- E: Tambourine
- D: Cabasa
- C: Cowbell
- B: Kick Drum
- A: Cajon Bass

ORTEGA ANALOG STOMP BOX - PERFECT FOR PLAYERS ON THE GO & STREET PERFORMERS

The Ortega **ANNAlog**® analog percussion stomp box is the perfect tool for guitarists, singer/songwriters and street performers wanting to add a percussive element to any performance. With it's analog design, no battery or power supply is needed. Plug-In and play. Detailed inner construction minimizes surrounding noise to maximize bass punch. Equipped with an input and output, the True Bypass allows you to blend the percussive sound with your instrument signal to a single channel.

ANNAlog

ANALOG STOMP BOX with built-in sound optimized piezo technology.

- **No battery or power supply needed**
- **Input & output - only one channel needed**
- Comfortable ergonomic design for foot tapping
- Solid cherry wood housing
- Non-slip bottom coating
- Minimized surrounding noise
- Maximized bass punch
- Sweeping volume control to adjust the level of bass punch
- 6.3 mm (1/4") input & output jack



Your **HANDS FREE** rhythm section

NO BATTERY or POWER SUPPLY needed!



PERCUSSION SERIES

MADE IN SPAIN

CAJONS – PERFORMER SERIES

NEW

Handcrafted in Spain, our new Ortega cajons feature exceptional craftsmanship and stunning looks and sound. The 9-Ply, 12 mm thick Baltic Birch resonating body develops the sound into a full, punchy tone that projects with clarity and warmth. When amplification is needed, the Performer Series cajons are equipped with a Piezo pickup with tone and volume controls accessible on the side. A quarter-inch cable port allows you to send your signal through any amp or PA system. **They are available in right and left-hand configurations.**

Resonating body: Baltic Birch

Front plate **OCJPF-2**: Cedar / Front plate **OCJPF-3**: Walnut

- Piezo pickup with volume and tone control
- Right and left-handed version
- Rounded corners and thumb notches for optimal playing comfort and sound
- Specially formulated soft rubber feet
- Ergonomically rounded front plate with convex contact
- Link allows you to input an additional instrument, independent from volume & tone, with pass-through capability
- Output / link jack: 6.3 mm (1/4")

CEDAR FRONT

LEFT HANDED



OCJPF-2



OCJPF-2L

WALNUT FRONT

LEFT HANDED



OCJPF-3



OCJPF-3L

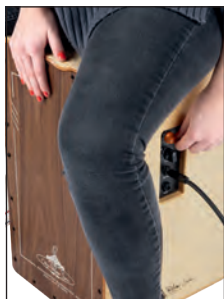
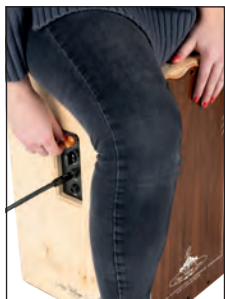

OCJPF-2L and OCJPF-3L optimized for left-handed people

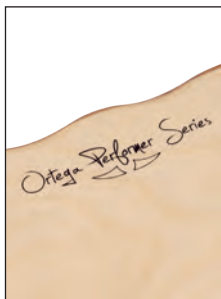

Top side



Soundhole



Rounded corners



Output / Link

CAJON BAGS



OGBCJ-BX



OGBCJ-OC



OGBCJ-MO

PREMIUM CAJON BAGS

NEW

Ortega premium CAJON BAGS are made with a canvas/cotton surface and feature a real suede leather inlay. The 10 mm (0.39") soft sponge padding securely protects your instrument from shock and damage. Equipped with a carrying handle and backpack straps, you can take your instrument with you anywhere you go.

- Material: canvas/cotton surface with suede leather inlay
- Padding: 10 mm
- Size (interior): width 345 mm (13.5") x height 450 mm (17.75") x depth 345 mm (13.5")

Colors: Bordeaux Wine (BX), Ocean Blue (OC), Mocca (MO)

STOMP BOX CAJON BUNDLE



OSTBCJ-BU

OSTBCJ-L-BU

**BUNDLE AVAILABLE
IN LEFT FOOT OR
RIGHT FOOT
CONFIGURATION**



Your
**HANDS
FREE**
rhythm section



RIGHT FOOT

LEFT FOOT

Our hands free percussion products are designed specifically for the stringed instrument player. Go busking in the streets, recording in a studio, jam with friends or write a song, adding percussive rhythm elements, all while playing your stringed instrument.

The **ORTEGA STOMP BOX CAJON BUNDLE OSTBCJ-BU & OSTBJ-L-BU** includes:

ORTEGA CAJON (with bundle only)
Size: 30 cm (11.75") W x 46 cm (18") H x 30 cm (11.75") D

Resonating body: Baltic Birch
Front plate **OSTBJ-BU**: Ammara wood
Front plate **OSTBJ-L-BU**: Baltic Birch (Golden Brown)

- 2 internal snare wires
- Adjustable front plate for more sound options
- Curved corners for more comfort
- Delivers full, rich tone
- Made in Europe

FREE Cajon backpack bag included!

ORTEGA CAJON PEDAL
OCJP-GB or OCJP-L-GB

- Heavy duty metal ground plate and metal pedal
- Soft foam beater (length adjustable)
- Cradle-like mount – fits all common Cajons
- Adjustable spring tension (pedal)

FREE Cajon pedal gig bag & drum key included!

CAJON BAG & PEDALS

PROFESSIONAL CAJON BAG

NEW

Professional cajon bag made from heavy duty nylon material. Thick padding inside, heavy duty zippers, wide and comfortable shoulder straps (adjustable) distinguishes this exclusive bag.

- Material: heavy-duty nylon
- Features: backpack straps
- Size (interior): width 343 mm (13.5") x height 500 mm (19.75") x depth 356 mm (14")

Color: Black



OSTCJB-BP

CAJON PEDAL

This pedal leaves your hands unrestricted to play along with your stringed instrument while keeping a steady kick drum rhythm beneath.

- Heavy duty metal ground plate and metal pedal
- Soft foam beater (length adjustable)
- Cradle-like mount – fits all common Cajons
- Adjustable spring tension (pedal)

FREE Cajon Pedal gig bag & drum key included!

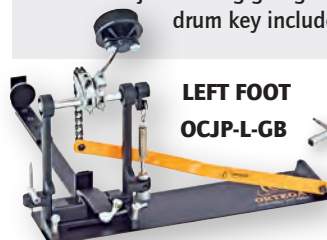

LEFT FOOT
OCJP-L-GB



RIGHT FOOT
OCJP-GB



PERCUSSION SERIES

ORTEGA KALIMBAS – LIZARD SERIES

Ortega handmade Kalimbas combine the legacy of its African origin with modern aspects. Carefully selected and spectacular looking solid acacia, ergonomically shaped handrest and a crystal clear tonal experience encourage unlimited creativity and musical enjoyment. A built-in pickup makes the OKB1E Kalimba perfect for live performances.



NEW

OKB1E



- Solid Acacia wood, all gloss finish
- Top soundhole with lasered Lizard rosette
- 17 Keys - C Major tuning
- Built-in passive electronics w/ output jack 6.3 mm (1/4")
- Includes deluxe case, cover bag, tuning hammer, polish cloth



PICKUP BUILT-IN

PICKUP BUILT-IN



OKB1

- Solid Acacia wood, all gloss finish
- Top soundhole with lasered Lizard rosette
- 17 Keys - C Major tuning
- Includes deluxe case, cover bag, tuning hammer, polish cloth



OKB2

- Solid Bamboo wood, all gloss finish
- Front soundhole
- Lizard top inlay
- 17 Keys - C Major tuning
- Includes deluxe case, cover bag, tuning hammer, polish cloth



OKB3

- Solid Golden Phoebe, all gloss finish
- Front soundhole
- Lizard top inlay
- 17 Keys - C Major tuning
- Includes deluxe case, cover bag, tuning hammer, polish cloth

EFFECT SERIES

The **wood finger shakers** and the **PVC finger shakers** are excellent additions to any instrumentalist's collection. Whether you're a guitarist, bassist, ukulele player, percussionist, or play any other instrument with your hands, this little device will add a percussive touch to every performance. Simply place it on your finger and play. The movement of your hand creates the effect on the beat.

WOOD FINGER SHAKER

The wood finger shaker is available in small or large, you can choose your volume level.

- Made from Cassia, red cedar and tiger wood, natural finish
- 2-3 mm stainless steel beads
- Comfortable to wear on your fingers
- Two sizes for different volume level

OFSW-S, small, 32 mm (1.26") x 25 mm (0.98") x 15 mm (0.59")

OFSW-L, large, 50 mm (1.97") x 26 mm (1.02") x 17 mm (0.67")



PVC FINGER SHAKER

Available in black sparkle finish (BKS) and blue sparkle finish (BLS).

- Comfortable to wear on your fingers
- Bright and clear sound
- 3 mm stainless steel beads

OFS-BKS and **OFS-BLS**, 39 mm (1.54") x Ø 25 mm (0.98")



GUITARIST FOOT TAMBOURINE

The Guitarist Foot Tambourine is the perfect match for any stringed instrument player. This light and versatile "hands free" rhythm tool delivers a bright cutting tone, yet not overpowering. Easily mounted on your foot, it will go with any beat.

- Made from rubber wood in Ortega orange
- Bright, light accent for any stringed instrument
- Ergonomic design and hassle-free mounting
- 4 pairs stainless steel jingles



OGFT



SINGER/SONGWRITER FOOT TAMBOURINE

The Singer/Songwriter Foot Tambourine is the perfect rhythm accessory for acoustic performances, studio applications or a fun jam session. The 5 pairs of stainless steel jingles deliver a precise, light shimmering sound in a small pocket friendly design.

- Made from rubber wood in Ortega orange
- Bright, light accent for any stringed instrument
- Ergonomic design and hassle-free mounting
- 5 pairs stainless steel jingles



OSSFT





POS



SW-W120-MA



ORUG

Universal slatwall brackets - applicable for many rail systems



OSWA-U-AD



OSWA-U-ST



OSWA-G-AD



OSWA-G-ST



OSWA-ACC



OSWA-ACC-5MM



ODECOFLAG70



DIS-ORUKE-10

SW-W120-MA Ortega point of sale display modular system, 250 cm (98.43") height, 120 cm (47.24") width. Ortega Slatwall modular system all parts:
1x SW-W120-MA | 2x SW-LT, feet | 1x SW-TF, feet extension (option for freestanding) | 1x SW-OP120/30, Ortega Guitars panel | 2x SW-W-SA240, side cover

OSWA-U-AD Slatwall hook for ukulele, long, adjustable

OSWA-U-ST Slatwall hook for ukulele, short, straight

OSWA-G-AD Slatwall hook for guitar, long, adjustable

OSWA-G-ST Slatwall hook for guitar, short, straight

OSWA-ACC Slatwall hook for accessories

OSWA-ACC-5MM Slatwall hook for accessories, long, 5 mm

DIS-ORUKE-10 Ortega ukulele display fits 10 ukuleles from soprano to baritone/Ukubass size, 200 cm (78.70") height, 65 cm (25.60") width

ODECOFLAG Ortega deco flag, 70 cm (27.56") height, 60 cm (23.62") width

ORUG Ortega shop/stage rug, 140 x 80 cm (55" x 32"), anti slip rubber bottom

ACCESSORIES

INDEX

ACCESSORIES	75	Picks & Slides	102
Strings	76	Tuners	104
Capos	79	Care	105
Straps	82	Humidifiers	
Vegan Straps		& Useful Helpers	107
& Accessories	87	Preamps & Pickups	109
Hangers, Stands, Holder	88	Cables & Power	110
Stools	90	Strap Locks & Pins	111
Bags & Cases	91	Tuning Machines	111
Digital Wireless Systems	98		
Cables	100		





STRINGS

ORTEGA GUITARS CUSTOM MADE STRINGS

ORTEGA Authentic, Select, and Pro strings are made with exclusive winding and polishing techniques. Our superior materials are globally sourced and produce a traditional rich, warm sound with a distinctive bright timbre.

Different colors for different instruments:



Nylon Guitar Strings



Guitarlele,
Mini | Travel Guitar Strings



Ukulele Strings



Acoustic Bass Strings



Mandolin Strings



Banjo Strings



3 different manufacturing categories:

Authentic

Our Authentic strings are a high quality, affordable option for nylon strings. These strings offer consistent tone and exceptional tuning stability and are great for beginners and intermediate players alike.

Select

Made from superior materials, Select strings are an excellent choice for players, who strive for a rich tone and a prolonged string life. The anti-rust coating prevents tarnishing and preserves the clear tone of new strings.

Pro

Pro strings offer the best available volume, tonal projection, and intonation for your stringed instrument. The anti-rust coating prevents tarnishing and preserves the clear tone of new strings.



NYLON STRING GUITAR



Authentic

Classical Guitar
Regular Nylon

NYA44N	full scale	normal	.028/.032/.040/.029/.035/.043
NYA44H	full scale	hard	.028/.033/.041/.030/.036/.044
NYA44EH	full scale	extra hard	.029/.033/.041/.030/.036/.047
NYA34N	3/4 scale	normal	.029/.033/.041/.030/.035/.044
NYA12N	1/2 scale	normal	.029/.033/.045/.030/.036/.046



Select

Classical Guitar
Coated, Regular Nylon

NYS44N	full scale	normal	.028/.032/.040/.029/.035/.043
NYS44H	full scale	hard	.028/.033/.041/.030/.036/.044
NYS44EH	full scale	extra hard	.029/.033/.041/.030/.036/.047
NYS34N	3/4 scale	normal	.029/.033/.041/.030/.035/.044
NYS12N	1/2 scale	normal	.029/.033/.045/.030/.036/.046



Pro

Classical Guitar
Coated, Crystal Nylon

NYP44N	full scale	normal	.028/.032/.040/.029/.035/.043
NYP44H	full scale	hard	.028/.033/.041/.030/.036/.044
NYP44EH	full scale	extra hard	.029/.033/.041/.030/.036/.047
NYP34N	3/4 scale	normal	.029/.033/.041/.030/.035/.044
NYP12N	1/2 scale	normal	.029/.033/.045/.030/.036/.046

NEW

8 STRING NYLON GUITAR



NYP8 Baritone scale normal
.029/.033/.045/.030/.036/.046/.060/.083

Pro

Classical Guitar
Coated, Crystal Nylon

NEW

REQUINTO GUITAR



RQS Requito scales normal
.029/.033/.041/.030/.035/.044

Select

Classical Guitar
Coated, Custom Nylon

NEW

GUITARLELE, MINI | TRAVEL GUITAR



GTLSBK black
.026/.031/.038/.027/.033/.040

GTLS normal clear
.026/.031/.038/.027/.033/.040

Classical Guitarlele & Mini | Travel Guitar
Coated, Custom or Black Nylon *Select*

NEW

ACOUSTIC BASS



ABP-4 4 string
.045/.065/.080/.100

ABP-5 5 string
.045/.065/.080/.100/.130

Acoustic Bass, Long scale
Coated, Phosphor Bronze *Pro*

NEW

UKULELE



Authentic

Ukulele
Clear or Black Nylon



Select

Ukulele
Custom or Black Nylon



Pro

Ukulele
Crystal Nylon

UKABK-SO Soprano Black .024/.030/.036/.026

UKABK-CC Concert Black .024/.030/.036/.026

UKA-SO Soprano Clear .024/.030/.036/.026

UKA-CC Concert Clear .024/.030/.036/.026

UKSBK-SO Soprano Black .024/.030/.036/.026

UKSBK-CC Concert Black .024/.031/.037/.026

UKSBK-TE Tenor Black .026/.032/.038/.028

UKSBK-BA Baritone Black .026/.036/.024/.030

UKS-SO Soprano Clear .024/.030/.036/.026

UKS-CC Concert Clear .024/.031/.037/.026

UKS-TE Tenor Clear .026/.032/.038/.028

UKS-BA Baritone Clear .026/.036/.024/.030

UKP-SO Soprano .024/.030/.036/.026

UKP-CC Concert .024/.031/.037/.026

UKP-TE Tenor .026/.032/.038/.028

UKP-BA Baritone .026/.036/.024/.030

NEW

MANDOLIN



MAP-8 8 string light
.010/.016/.023/.034

Mandolin
Coated, Loop ends, Phosphor Bronze *Pro*

NEW

BANJO/GUITAR BANJO



BJP-5 5 string medium
.010/.012/.014/.022/.010

GBJP-6 6 string medium
.011/.014/.020/.032/.042/.052

Banjo/Guitar Banjo
Coated, Loop ends, Phosphor Bronze *Pro*



STRINGS

ATMOSPHERE

6STRING GUITAR



ATG44NM



ATG44NH

ATMOSPHERE green - a revolutionary step in achieving the ultimate Organic Sound!

ORTEGA Guitars atmosphere green strings are created and manufactured in Italy. We replaced the usually oil based treble strings with a newly developed nylon material which is made from 100% plant-based products. Our Atmosphere Green strings deliver a perfect combination of bright, warmth, punchy tone and incredible projection. Precise intonation and long-lasting tuning stability add to their exceptional playability.

Our small but important contribution for a cleaner and greener planet.

ATG44NM (MEDIUM) Diameter .042 w .034 w .028 w .040 .032 .028

ATG44NH (HARD) Diameter .043 w .035 w .028 w .041 .033 .029

6STRING GUITAR



ATB44NM



ATB44NH

ATMOSPHERE balance - a revolutionary step in achieving the ultimate BALANCED TONE!

Through our intensive engineering process, we calculate the windings, thickness, and core of the 3 bass strings. This process creates additional flexibility which increases vibration and resonance, ultimately delivering an extraordinary brightness and crystal-clear tonal experience. This creates a fully balanced string which delivers superior feel and tone. All Ortega professional nylon strings are proudly produced with traditional German craftsmanship.

ATB44NM (MEDIUM)

Item-No.	ATB44NM-E6	ATB44NM-A5	ATB44NM-D4	ATB44NM-G3	ATB44NM-B2	ATB44NM-E1
Diameter	.043 w	.035 w	.029 w	.039	.031	.028
Tension (lbs)	13.89	13.89	13.67	11.46	11.68	15.87

ATB44NH (HARD)

Item-No.	ATB44NH-E6	ATB44NH-A5	ATB44NH-D4	ATB44NH-G3	ATB44NH-B2	ATB44NH-E1
Diameter	.044 w	.036 w	.030 w	.039	.031	.028
Tension (lbs)	14.77	14.77	14.99	11.46	11.68	15.87



Single strings available

4STRING UKULELE



UWN4-SO

ORTEGA white nylon series combine the perfect combination of warm yet punchy tone.

SOPRANO:
UWN4-SO .026/.037/.032/.024

CONCERT:
UWN4-CC .027/.038/.032/.024

TENOR:
UWN4-TE .028/.038/.032/.026

BARITONE:
UWN4-BA w/w/.032/.027

6 & 8STRING TENOR UKULELE



UNY6-TE

ORTEGA nylon series ukulele strings combine the perfect combination of warm yet punchy tone. Precise intonation, tuning stability and comfortable playability are the cornerstones of ORTEGA ukulele strings.

Custom made for 6 & 8string tenor scale.

UNY6-TE .027/.037/.019/.033/.040/.025

UNY8-TE .041/.026/.037/.019/.031/.031/.025/.025

8STRING NYLON GUITAR



8string nylon string guitar set - Made in Germany. Custom made of the finest materials, with great precision and HANDCRAFTED by experts. Optimized for 690 mm scale. E/B/E/A/d silver plated copper wound on nylon silk g/b/e - nylon rectified.

OCTA8NS .029/.032/.041/.031/.037/.046/.060/.083

6STRING GUITARLELE



GLNY-6

ORTEGA Guitarlele strings combine the perfect combination of warm yet punchy tone. Precise intonation, tuning stability and comfortable playability are the cornerstones of ORTEGA Guitarlele strings.

Perfect for 420 mm - 440 mm scale.

GLNY-6 .041/.033/.027/.038/.032/.026

4STRING ACOUSTIC BASS



Custom made in Germany for short scale acoustic basses (up to 25"). Silver plated copper wound on nylon silk.

ODW-4 .043/.059/.071/.080 fully balanced strings 5.5 kg (12.12 Lbs)

Custom developed for D-Walker bass!





TNCAPO-BCR

NEW



TNCAPOCV-BCR

NEW



Bag included

CAPOS TRUE NOTE

Our True Note capos are simple to use and provide your guitar with unrivaled tuning stability. The capos can be installed in seconds using the QUICK-LOCK system. The applications include classical guitars, nylon-string guitars, steel-string guitars, and 12-string acoustic guitars. The capos are available in two variations: TNCAPO-BCR for flat fretboards and TNCAPOCV-BCR for curved fretboards, both in an elegant black chrome finish.

- Capo for flat fretboards up to 52 mm nut width
- Black Chrome Edition
- High grade alloy over aluminum
- Player optimized spring and pressure
- Unrivaled tuning stability

TNCAPO-BCR

TRUE NOTE capo flat, black chrome

TNCAPOCV-BCR

TRUE NOTE capo curved, black chrome



OCAPO-CR



OCAPO-SBK



OCAPO-MAD



OCAPO-WND



Bag included

CAPOS FLAT

Easily adjustable design made of aluminum alloy and silicone cushion. FLAT fretboard up to 52 mm nut width.

OCAPO-CR

Chrome

OCAPO-SBK

Satin black

OCAPO-MAD

Maple Design

OCAPO-WND

Walnut Design



CAPOS



OCAPOCV-CR



OCAPOCV-SBK



12string proofed



OCAPOCV-MAD



OCAPOCV-WND



Bag included

CAPOS CURVED

Easily adjustable design made of aluminum alloy and silicone cushion. CURVED (radius) fretboard up to 52 mm nut width.

OCAPOCV-CR

Chrome

OCAPOCV-SBK

Satin black

OCAPOCV-MAD

Maple Design

OCAPOCV-WND

Walnut Design



TWCAPO-CR



TWCAPO-SBK



TWCAPO-MAD



TWCAPO-WND

2 IN 1

ONE CAPO FOR CURVED + FLAT FRETBOARDS

TWINCAPOS CURVED/FLAT

Ortega Guitars' TWINcapo is not a one-trick-pony! It covers flat fretboards as well as curved fretboards. Available in satin black/orange, gloss chrome/black, maple design/black & walnut design/black.

- High-grade alloy
- Covers FLAT & CURVED/RADIUS fretboards
- Perfect silicone cushion
- Designed for acoustic guitars, classic guitars (up to 52 mm nut) & electric guitars

TWCAPO-CR

Chrome/black silicone cushion

TWCAPO-SBK

Satin black/orange silicone cushion

TWCAPO-MAD

Maple Design/black silicone cushion

TWCAPO-WND

Walnut Design/black silicone cushion



Bag included



Flat



Curved



SMCPAD-OR



SMCPADCV-SBK



Bag included

CAPOS SPIDER MONKEY CAPO

Made of aluminum alloy the "SPIDER MONKEY" Capos allow micro adjustment for exact tension. Together with a perfect silicone cushion the need to retune the instrument is dramatically reduced.

SMCPAD-OR

Designed for FLAT fretboards, up to 52 mm width at nut

SMCPADCV-SBK

Designed for CURVED (radius) fretboards, up to 52 mm width at nut

CAPO UKULELE/BANJO/MANDOLIN

Easily adjustable design made of aluminum alloy and silicone cushion. Optimized for Ukulele, Banjo and Mandolin.

OCAPOUKE-CR

Chrome

OCAPOUKE-SBK

Satin black

OCAPOUKE-MAD

Maple Design

OCAPOUKE-WND

Walnut Design



OCAPOUKE-CR OCAPOUKE-SBK



OCAPOUKE-MAD OCAPOUKE-WND



Bag included

CAPO BLUEGRASS (MANDOLIN & BANJO)

BGCAPO

brushed brass bluegrass capo

- Optimized for Banjo and Mandolin



BGCAPO



Bag included

CAPOS FLAT/CURVED/UKULELE & BANJO

SPECIAL EDITION of the ever popular ORTEGA CAPO Series features a stunning BLACK CHROME surface over aluminum and a premium presentation gift box.

Easily adjustable design made of aluminum alloy with a silicone cushion.

Available versions:

OCAPO-BCR - FLAT (classic, fretboards up to 52 mm nut width)

OCAPOCV-BCR - CURVED (radius fretboards up to 52 mm nut width)

OCAPOUKE-BCR - optimized for Ukulele & Banjo

THE BLACK CHROME EDITION INCLUDES A PREMIUM PRESENTATION GIFT BOX



OCAPO-BCR



OCAPOCV-BCR



OCAPOUKE-BCR





GUITAR STRAPS - HANDPICKED LEATHER

ORTEGA GUITARS LEATHER STRAPS

The new Ortega suede and genuine leather straps are handmade in Brazil and offer a great look and feel. Thanks to the thick padding, your playing experience will be extra comfortable, even during long practice and studio sessions, and live performances. These beautiful designs are absolute eye-catchers.

- Handpicked Suede and Genuine leather
- Handmade in Brazil
- 2 or 3 layers



LEATHER STRAPS - SUEDE SERIES

2 layers

DIMENSIONS (cm/inch)

Width: 6/2.36

Min. length: 92/36.22

Max. length: 145/57.08



NEW



OSSU-10
"ash"



OSSU-20
"peat"



OSSU-30
"caramel"



OSSU-40
"cognac"



OSSU-50
"vintage malt"



OSSU-60
"relax black"



OSSU-70
"patina bronze"

LEATHER STRAPS - CUSTOM SERIES

3 layers

DIMENSIONS (cm/inch)

Width: 7/2.75

Min. length: 92/36.22

Max. length: 145/57.08



NEW



OSCU-1
3 layers
"dark brown croco"



OSCU-2
3 layers
"natural brown flora"



OSCU-3
3 layers
"dark brown lizzy"



OSCU-4
3 layers
"black braid"



OSCU-5
3 layers
"tan braid"



OSCU-6
3 layers
"orange braid"

GUITAR STRAPS - HANDPICKED LEATHER

LEATHER STRAPS - BYZANTINE SERIES

2 layers

DIMENSIONS (cm/inch)

Width: 7/2.75

Min. length: 92/36.22

Max. length: 145/57.08



NEW



OSBY-1
2 layers
"byzantine black"



OSBY-2
2 layers
"byzantine cocoa"



OSBY-3
2 layers
"byzantine fire"



OSBY-4
2 layers
"byzantine bourbon"



OSBY-5
2 layers
"byzantine bordeaux"



OSBY-6
2 layers
"byzantine brown"

LEATHER STRAPS - CLASSIC SERIES

2 layers

DIMENSIONS (cm/inch)

Width: 7/2.75

Min. length: 92/36.22

Max. length: 145/57.08



NEW



OSCL-1
2 layers
"roman marble"



OSCL-2
2 layers
"chestnut tree"



OSCL-3
2 layers
"vintage ash"



OSCL-4
2 layers
"vintage brown"



OSCL-5
2 layers
"vintage caramel"



OSCL-6
2 layers
"vintage bronze"



OSCL-7
2 layers
"vintage cognac"

LEATHER STRAPS - ARTIST SERIES

3 layers

DIMENSIONS (cm/inch)

Width: 7/2.75

Min. length: 92/36.22

Max. length: 145/57.08



NEW



OSAR-1
3 layers
"black hole"

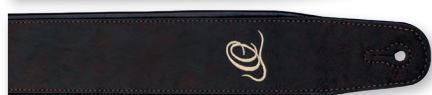

OSAR-2
3 layers
"deep forest brown"



OSAR-3
3 layers
"dessert stone"

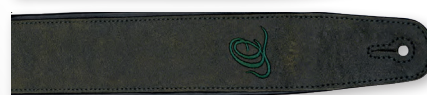

OSAR-4
3 layers
"olive tree"



OSAR-5
3 layers
"highland chocolate"



OSAR-6
3 layers
"vintage desert sand"



OSAR-7
3 layers
"sand blasted rock"



GUITAR STRAPS - COTTON

COTTON STRAPS - HIGHLAND SERIES

Made from 100% cotton and equipped with strong FAUX LEATHER ends. 49 mm (1.93") width, up to 1580 mm (62.2") length, embossed logo.



OCS-100
"faded pink"

OCS-110
"stars"



OCS-120
"faded grey"

OCS-130
"faded brown"

OCS-140
"scottish dark"

OCS-150
"scottish bright"

COTTON STRAPS - CASUAL SERIES

Made from 100% cotton and equipped with strong FAUX LEATHER ends. 49 mm (1.93") width, up to 1580 mm (62.2") length, embossed logo.



OCS-200
"coal cotton"

OCS-210
"grey cotton"

OCS-220
"brown cotton"

OCS-230
"ice cotton"

OCS-240
"khaki cotton"

OCS-250
"burgundy cotton"

OCS-260
"orange cotton"

OCS-270
"blue cotton"

COTTON STRAPS - WORLD SERIES

Made from 100% cotton and equipped with strong FAUX LEATHER ends. 49 mm (1.93") width, up to 1580 mm (62.2") length, embossed logo.



OCS-400
"indian sky"

OCS-410
"indian arts"

OCS-420
"desert night"

OCS-430
"frisco dance"

OCS-440
"african dance"

OCS-450
"icelander"

OCS-460
"machu pichu"

OCS-470
"maya dance"

COTTON STRAPS - SPRING SERIES

Made from 100% cotton and equipped with strong FAUX LEATHER ends. 49 mm (1.93") width, up to 1580 mm (62.2") length, embossed logo.



OCS-300
"coal jean"

OCS-310
"brown jean"

OCS-320
"pink jean"

OCS-330
"sun jean"

OCS-340
"green jean"

OCS-350
"blue jean"

OCS-360
"purple jean"

COTTON STRAPS - CREATIVE SERIES

Made from 100% cotton and equipped with strong FAUX LEATHER ends. 49 mm (1.93") width, up to 1580 mm (62.2") length, embossed logo.



OCS-500
"striped"

OCS-510
"modern arts"

OCS-520
"70's psycho"

OCS-530
"70's plants"

OCS-540
"classic white"

OCS-550
"classic blue"

OCS-560
"classic yellow"



ALL cotton guitar straps incl. pick holder pocket

NYLON STRAPS UNICOLOR

50 mm (1.97") width, leather ends with embossed Logo, up to 1800 mm (70.86") length



- ONS50STD-BK**
"black"
- ONS50STD-BR**
"brown"
- ONS50STD-WH**
"white"
- ONS50STD-RD**
"red"
- ONS50STD-BL**
"blue"

NYLON GUITAR STRAPS/SUPPORT - HOOK

Special nylon made acoustic guitar strap with soundhole hook. 37 mm (1.45") width at upper part.

The strap/support is appx. 800 mm (31.5") long and adjustable up to appx. 1000 mm (39").



- OGSHK-BK**
"black"
- OGSHK-BR**
"brown"



UKULELE STRAPS - COTTON

COTTON UKULELE STRAPS - HIGHLAND SERIES

Made from 100% cotton and equipped with strong FAUX LEATHER ends. 37 mm (1.45") width, up to 1390 mm (54.33") length, embossed logo.



- OCS-100U**
"faded pink"
- OCS-110U**
"stars"



- OCS-120U**
"faded grey"
- OCS-130U**
"faded brown"
- OCS-140U**
"scottish dark"
- OCS-150U**
"scottish bright"

COTTON UKULELE STRAPS - CASUAL SERIES

Made from 100 % cotton and equipped with strong FAUX LEATHER ends. 37 mm (1.45") width, up to 1390 mm (54.33") length, embossed logo.



- OCS-200U**
"coal cotton"
- OCS-210U**
"grey cotton"
- OCS-220U**
"brown cotton"



- OCS-230U**
"ice cotton"
- OCS-240U**
"khaki cotton"
- OCS-250U**
"burgundy cotton"
- OCS-260U**
"orange cotton"
- OCS-270U**
"blue cotton"

COTTON UKULELE STRAPS - WORLD SERIES

Made from 100 % cotton and equipped with strong FAUX LEATHER ends. 37 mm (1.45") width, up to 1390 mm (54.33") length, embossed logo.



- OCS-400U**
"indian sky"
- OCS-410U**
"indian arts"
- OCS-420U**
"desert night"



- OCS-430U**
"frisco dance"
- OCS-440U**
"african dance"
- OCS-450U**
"icelander"
- OCS-460U**
"machu pichu"
- OCS-470U**
"maya dance"



UKULELE STRAPS - COTTON & NYLON

COTTON UKULELE STRAPS - SPRING SERIES

Made from 100% cotton and equipped with strong FAUX LEATHER ends. 37 mm (1.45") width, up to 1390 mm (54.33") length, embossed logo.



OCS-300U
"coal jean"

OCS-310U
"brown jean"

OCS-320U
"pink jean"

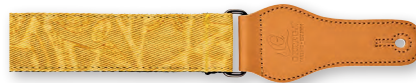

OCS-330U
"sun jean"

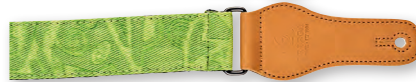

OCS-340U
"green jean"



OCS-350U
"blue jean"



OCS-360U
"purple jean"

COTTON UKULELE STRAPS - CREATIVE SERIES

Made from 100% cotton and equipped with strong FAUX LEATHER ends. 37 mm (1.45") width, up to 1390 mm (54.33") length, embossed logo.



OCS-500U
"striped"

OCS-510U
"modern arts"

OCS-520U
"70's psycho"



OCS-530U
"70's plants"



OCS-540U
"classic white"



OCS-550U
"classic blue"



OCS-560U
"classic yellow"

NYLON UKULELE STRAPS/SUPPORT HOOK

Special "slim" nylon uke strap with soundhole hook, 37 mm (1.45") width at upper part, up to 700 mm (27.56") length



OUSHK-BK
"black"

OUSHK-BR
"brown"

OUSHK-WH
"white"

OUSHK-RD
"red"

OUSHK-BL
"blue"



NYLON UKULELE STRAPS

Special "slim" nylon uke straps, leather ends, 37 mm (1.45") width, up to 1350 mm (53.15") length



OUS-GRFL
"green flower"

OUS-MAY
"maya"

OUS-ORFL
"orange flower"

OUS-PALM
"palm island"

OUS-PUFL
"purple flower"

OUS-SUN
"sundown"

OUS-VOO
"voodoo"

MANDOLIN & BANJO STRAPS - LEATHER

MANDOLIN STRAPS

Leather, up to 1700 mm (66.92") length



OSM-BK
standard, black

OSM-BR
standard, brown

OSMDLX-BK
deluxe, padded shoulder, black

OSMDLX-BR
deluxe, padded shoulder, brown

BANJO STRAPS

60 mm (2.36") width, up to 1300 mm (51.18") length



OBJS-BK
banjo strap standard, genuine suede leather, carabiner (2x)

OBJSDLX-BK
banjo strap deluxe, genuine suede leather, padded carabiner (2x)

100% PHTHALATE FREE! 100% HYDROLYSIS FREE! 100% RECYCLABLE!

VEGAN PREMIUM

A new revolutionary vegan laminated synthetic material is the basis for one of the world's first ECO-friendly straps.

The unique and patented material feels so much like leather that it is nearly impossible to tell the difference.



We also offer vegan care products (see page 105).

ECONOMICAL & ENVIRONMENTALLY FRIENDLY

This technology is based on the latest generation of phthalate-free PVC (Polyvinyl Chloride).

100% RECYCLABLE

This material can be totally recycled and reused.

PVC MATERIAL FEATURES

- Vegan
- Resistant to fungi, bacteria & insects
- Weather resistant
- Durable
- Made with low power consumption
- Recyclable



GUITAR/BASS STRAPS – VEGAN SERIES

With embroidered logo. 60 mm (2.36") width, length up to 1460 mm (57.48").



OSVG-BK
black



OSVG-TN
tan



OSVG-BR
brown



OSVG-RD
red

UKULELE STRAPS – VEGAN SERIES

With embroidered logo. 40 mm (1.57") width, length up to 1360 mm (53.55"). Includes CONNECT Headstock Tie, to securely attach the strap to your headstock.



OSVU-BK black
CONNECT Headstock Tie included



OSVU-TN tan
CONNECT Headstock Tie included



OSVU-BR brown
CONNECT Headstock Tie included



OSVU-RD red
CONNECT Headstock Tie included

GUITAR/BASS STRAPS – VEGAN SERIES

Extra wide. 75 mm (3.00") width, length up to 1460 mm (57.48").



OSVG-75BK
black



OSVG-75TN
tan



OSVG-75BR
brown



OSVG-75RD
red

CONNECT – VEGAN SERIES

VEGAN headstock strap connector. Perfect to attach your strap on the headstock of guitars, ukuleles, mandolins and other stringed instruments. NO additional strap button needed on the heel of instrument.



CONNECT-BK
black



CONNECT-TN
tan



Guitar



Ukulele



HANGERS & STANDS

WALL HANGER

Easy to mount with included screws and drywall anchors. Soft padded cradle support.

Wall hanger, straight



NEW

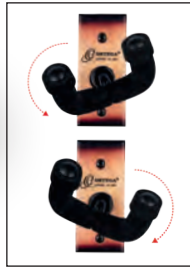

Guitar/Bass	Ukulele	
OGH-1WN	OUH-1WN	Walnut wood base, natural
OGH-1CW	OUH-1CW	Cherry wood base, natural
OGH-1	OUH-1	Wood base, black
OGH-1WH	OUH-1WH	Wood base, white
OGH-1WR	OUH-1WR	Wood base, wine red
OGH-1CSB	OUH-1CSB	Wood base, cherry sunburst
OGH-1TSB	OUH-1TSB	Wood base, tobacco sunburst
OGH-1NT	OUH-1NT	Natural birch, gloss

GUITAR:

UKULELE:



OGH-1NT

NEW



OGH-1TSB



OGH-1



OGH-1CW



OGH-1WH



OGH-1WR



OGH-1WN



OGH-1CSB



Ouh-1NT

NEW



Ouh-1CSB



Ouh-1



Ouh-1CW



Ouh-1WH



Ouh-1WR



Ouh-1WN



Ouh-1TSB



ADJUSTABLE WALL HANGER

Easy to mount with included screws and drywall anchors. Soft padded cradle support. OGHAD-1 models have a boom and are angle adjustable. Now available in two additional wood bases.

OGHAD-1 Wood base, black, adjustable angle

OGHAD-1CW Wood base, adjustable angle, 170 mm/6.69", Cherry wood, natural

OGHAD-1WN Wood base, adjustable angle, 170 mm/6.69", Walnut wood, natural



OGHAD-1CW



OGHAD-1WN



OGHAD-1



HOLDER OMUH-BK

Ukulele holder for microphone, guitar and music stands.

Holder easily clips onto stand. Fits all size ukuleles as well as mandolins or other small folk instruments. Extra strong clamp system and soft padded cradle support.

Color: all black



OMUH-BK



WOODEN GUITAR/UKE STANDS

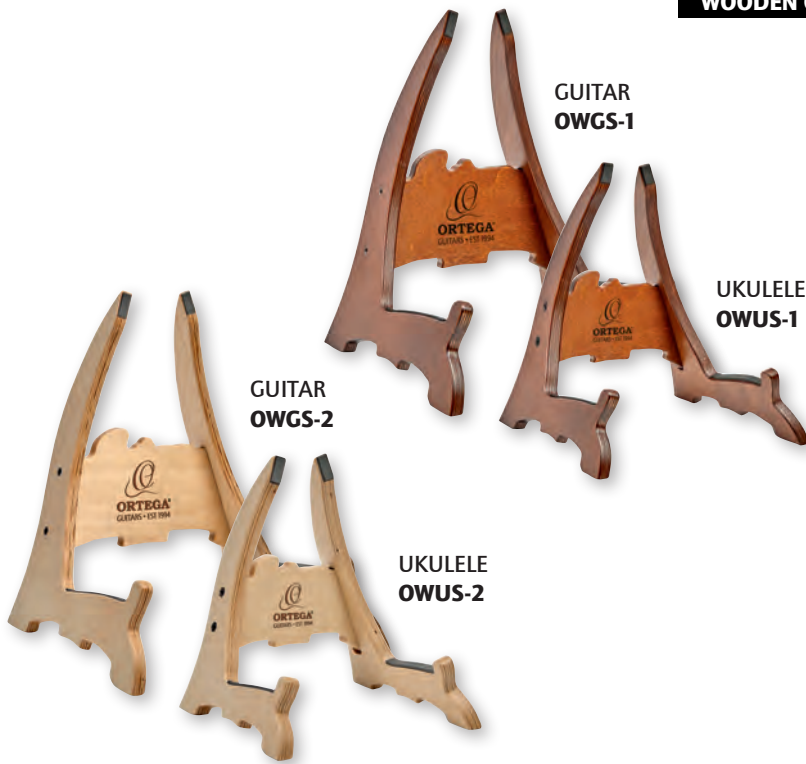

The perfect stand for home, office and shop. Made from birch, the Ortega guitar stand is as beautiful as it is supportive. Soft and safe "anti-slip" padding for best protection. Assembles in minutes (screws included).

OWGS-1/OWUS-1

birch, dark brown

OWGS-2/OWUS-2

birch, natural bright



PORTABLE GUITAR/UKE STANDS



Made with extremely lightweight and strong synthetic material. Fits all sizes of guitars, basses, ukuleles, mandolins & more. Divided body rest for electric or acoustic guitars (OPGS) and easy to fold.

4 STEPS AND YOU'RE DONE!

GUITAR: OPGS-1BK

full black

OPGS-1ORBK

Ortega orange/black

UKULELE: OPUS-1BK

full black

OPUS-1ORBK

Ortega orange/black

*) not available in the US!

GUITAR STAND



- Lightweight and durable steel tubing covered with soft black neoprene rubber tubing to protect your instrument. Folds down for easy transport and storage
- Security strap/neck included

OGS1-BK

Guitar stand, black with orange tripod & orange feet buttons.

GUITAR STAND



NEW



- Conveniently showcases your acoustic, electric, or bass guitar
- Great for alternative instrument shapes, too
- Durable enough for use on the road
- Portable and efficient
- One grip fast height adjustable yoke
- Adjustable for any scale length
- Easily collapsible for convenient transportation and space-saving

OGS-2BK

Deluxe hanging guitar stand, black with orange tripod & orange feet buttons, incl. color box.

(for temporary use only, some finishes such as Nitrocellulose are not recommended to use with these stands)



STANDS, HOLDER & STOOLS

MUSIC STAND OMS-1BK



The Ortega portable music stand for the traveling musician or student on the go. Easy to use with 3 seamless tubes for adjusting height, a strong tripod base and a large book tray. FREE bag included.

- Made of lightweight, non-corrosive aluminum
- Height adjustable from 57 cm (22") to 127 cm (50")
- Book tray: 43.5 cm (17.13") x 22 cm (8.66")

OMS-1BK

ORTEGA TABLET HOLDER – DELUXE VERSION OTBH-DLX



Tablet holder with gooseneck and incl. clamp.

- Heavy duty, universal tablet holder
- Suitable for almost all tablet computers up to 13" displays
- Strong flexible goose neck
- Freely adjustable/rotatable tablet holder
- Mount to a stand/microphone stand with standard 5/8 thread or with included clamp (up to 35 mm/1.38" diameter)

OTBH-DLX

AMP STANDS



NEW

OAS

NEW

OAS-FL

Our new amp stands are the perfect solution for playing amplified guitar at home or on stage. Their stylish design better directs the sound coming from the speaker. You'll hear the difference. The deluxe version is also height adjustable.

OAS-FL, angled floor amp stand

- Loadable up to max. 40 kg (88.18 lbs)
- Improves the radiation angle of your combo
- Can be folded flat
- Inclination of the amplifier: approx. 28 degrees
- Width of the support surface approx. 20 cm (7.87")
- Folded dimensions: (W x H x D) 31 cm (12.20") x 3 cm (1.18") x 63.5 cm (25")
- Dimensions assembled (W x H x D): 31 cm (12.20") x 35 cm (13.77") x 47 cm (18.50")
- Material: steel
- Color: black

OAS, height adjustable heavy load amp stand; deluxe version

- Max. Load capacity: 70 kg (154,32 lbs)
- Flattened rubber feet dampen unwanted vibrations and provide additional stability
- Width of the support surface approx. 30.5 cm (12")
- Depth of the support surface approx. 20.5 cm (8,07")
- Inclination of the amplifier: approx. 25 degrees
- Dimensions assembled (W x H x D): 51 cm (20.07") x 90 cm (35.43") x 41.5 cm (16.34")
- Material: steel
- Height of the support surface adjustable from approx. 49 cm (19.29") in 3 steps to approx. 62 cm (24.41")
- Height adjustment with string spring supported locking screw

STOOLS

Ortega bar stools are made of plated metal tubes and feature a thick padded rotating seat. The additional footrest offers ideal seating for best playing comfort. They are a practical "eyecatcher" for stage, in-shop presentation or to use at your kitchen bar.

FOOTSTOOL



OWFS-1WR

OWFS-1NT

Ortega headstock shaped wooden footstool

- OWFS-1WR** wine red
- OWFS-1NT** natural



NEW

OBS24-WHKC

"white kaleidoscope"
61 cm (24")

OBS30-WHKC

"white kaleidoscope"
76 cm (30")



NEW

OBS24-BLKC

"blue kaleidoscope"
61 cm (24")

OBS30-BLKC

"blue kaleidoscope"
76 cm (30")



OBS24V2

"vintage brown"
61 cm (24")

OBS30V2

"vintage brown"
76 cm (30")



GIG BAGS

DELUXE GIG BAGS

Our new deluxe gig bags have a beautiful cotton fabric and provide superior, lightweight protection for stringed instruments. The gig bag securely protects your instrument from shock and water damage with a water-repellent surface and thick padding. Options for classical guitars, steel-string guitars, electric guitars, electric basses, and acoustic basses are all offered in this new collection. Additional foam pieces are included in the deluxe acoustic bass bag to adjust the inside measurement for different instrument sizes.

Available in 2 attractive colors:

BLACK (BK) – GREY (GY)

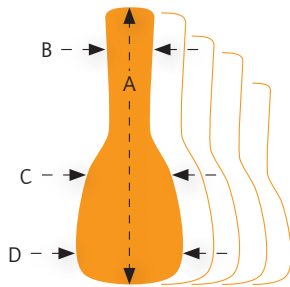

Padded shoulder straps



Hook & loop fastener for shoulder straps



Soft padding inside, Rubber bottom/shock protection

DIMENSIONS

ACOUSTIC DREADNOUGHT	A	B	C	D	Height
OGBDN-DLX-BK dreadnought	107.0 cm 42.13"	18.0 cm 7.08"	34.0 cm 13.38"	43.0 cm 16.92"	12.0 cm 4.72"
OGBDN-DLX-GY dreadnought	107.0 cm 42.13"	18.0 cm 7.08"	34.0 cm 13.38"	43.0 cm 16.92"	12.0 cm 4.72"
CLASSICAL	A	B	C	D	Height
OGBCL-DLX-BK regular classic size	103.0 cm 40.55"	16.0 cm 6.29"	31.0 cm 12.2"	38.0 cm 14.96"	10.0 cm 3.93"
OGBCL-DLX-GY regular classic size	103.0 cm 40.55"	16.0 cm 6.29"	31.0 cm 12.2"	38.0 cm 14.96"	10.0 cm 3.93"
E-GUITAR	A	B	C	D	Height
OGBEG-DLX-BK electric guitar	102.0 cm 40.15"	16.0 cm 6.29"	29.0 cm 11.41"	35.0 cm 13.77"	6.0 cm 2.36"
OGBEG-DLX-GY electric guitar	102.0 cm 40.15"	16.0 cm 6.29"	29.0 cm 11.41"	35.0 cm 13.77"	6.0 cm 2.36"
ACOUSTIC BASS	A	B	C	D	Height
OGBAB-DLX-BK acoustic bass	128.0 cm 50.39"	18.0 cm 7.08"	40.0 cm 15.74"	48.0 cm 18.89"	15.0 cm 5.9"
OGBAB-DLX-GY acoustic bass	128.0 cm 50.39"	18.0 cm 7.08"	40.0 cm 15.74"	48.0 cm 18.89"	15.0 cm 5.9"
E-BASS	A	B	C	D	Height
OGBEB-DLX-BK electric bass	122.0 cm 48.03"	16.0 cm 6.29"	31.0 cm 12.2"	37.5 cm 14.76"	6.0 cm 2.36"
OGBEB-DLX-GY electric bass	122.0 cm 48.03"	16.0 cm 6.29"	31.0 cm 12.2"	37.5 cm 14.76"	6.0 cm 2.36"



BAGS SOFT CASES



GUITAR

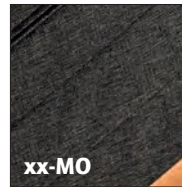

xx-MO

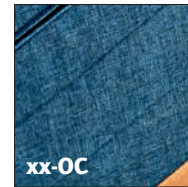

xx-OC

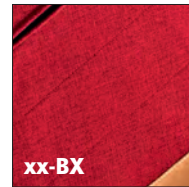

xx-BX



UKULELE



SOFT CASES

Travel in style with hard-case like protection with significantly less weight!

Ortega premium SOFT CASES are made with a canvas/cotton surface and real suede leather inlays. The 22 mm (0.86") soft sponge padding is supported by a 5 mm (0.20") hardened PE plastic frame. A plush black velvet material interior includes a neck brace with Velcro safety straps. The exterior features heavy duty zippers, comfortable, adjustable shoulder straps, a suede leather covered handle and two front compartments (one for ukulele sizes).

Available in 3 attractive colors:

MOCCA (MO) - OCEAN BLUE (OC) - BORDEAUX WINE (BX)



BANJO

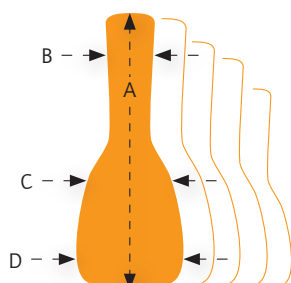

DIMENSIONS

ACOUSTIC DREADNOUGHT	A	B	C	D	Height
OSOCADN-xx dreadnought	107.0 cm 42.13"	14.0 cm 5.51"	33.0 cm 12.99"	42.0 cm 16.54"	13.0 cm 5.12"
CLASSICAL	A	B	C	D	Height
OSOCACL34-xx classic 3/4 size	92.5 cm 36.42"	12.0 cm 4.72"	25.0 cm 9.84"	36.5 cm 14.37"	12.0 cm 4.72"
OSOCACL-xx regular classic size	103.5 cm 40.75"	12.0 cm 4.72"	31.0 cm 12.2"	39.0 cm 15.35"	11.5 cm 4.53"
UKULELE	A	B	C	D	Height
OSOCAUK-SO-xx soprano	55.0 cm 21.65"	9.0 cm 3.54"	13.5 cm 5.31"	19.0 cm 7.48"	9.0 cm 3.54"
OSOCAUK-CC-xx concert	64.0 cm 25.2"	10.0 cm 3.94"	14.5 cm 5.71"	22.0 cm 8.66"	9.5 cm 3.74"
OSOCAUK-TE-xx tenor	67.5 cm 26.57"	10.0 cm 3.94"	16.0 cm 6.3"	23.0 cm 9.06"	10.0 cm 3.94"
BANJO	A	B	C	D	Height
OSOCABJ-xx classic 3/4 size	92.5 cm 36.42"	12.0 cm 4.72"	25.0 cm 9.84"	36.5 cm 14.37"	12.0 cm 4.72"



GUITAR

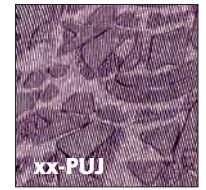
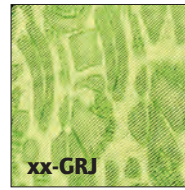
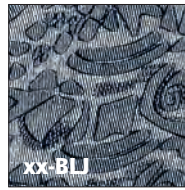

UKULELE



JEAN COLOR BAGS

Travel in style with great protection.

Ortega JEAN BAGS are made with a canvas/cotton surface decorated in fun stonewashed denim colors, covering a 12 mm (0.47") soft padding. A soft, black nylon interior includes a neck brace with Velcro safety straps. The exterior features heavy duty zippers, comfortable, adjustable shoulder straps, and a large front storage pocket.

Available in 4 fantastic colors:

BLUE JEAN (**BLJ**) - GREEN JEAN (**GRJ**) - SUN JEAN (**SUJ**) - PURPLE JEAN (**PUJ**)

front compartment



guitar



ukulele

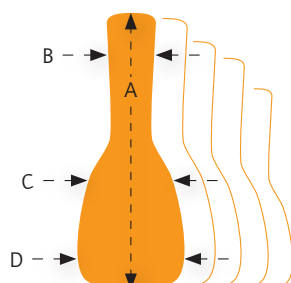

DIMENSIONS

ACOUSTIC DREADNOUGHT	A	B	C	D	Height
OGBAC-DN-xx dreadnought	107.0 cm 42.13"	14.0 cm 5.51"	33.0 cm 12.99"	42.0 cm 16.54"	13.0 cm 5.12"
CLASSICAL	A	B	C	D	Height
OGBCL-xx regular classic size	108.0 cm 42.52"	13.0 cm 5.12"	31.0 cm 12.2"	39.0 cm 15.35"	14.0 cm 5.51"
UKULELE	A	B	C	D	Height
OUB-SO-xx soprano	56.0 cm 22.05"	10.0 cm 3.94"	13.0 cm 5.12"	19.0 cm 7.48"	6.0 cm 2.36"
OUB-CC-xx concert	66.0 cm 25.98"	10.0 cm 3.94"	16.5 cm 6.5"	23.0 cm 9.06"	8.0 cm 3.15"
OUB-TE-xx tenor	69.0 cm 27.17"	10.0 cm 3.94"	17.5 cm 6.89"	24.0 cm 9.45"	8.0 cm 3.15"



BAGS ECONOMY / PRO

GUITAR BAGS ECONOMY OGBSTD-xx



OGBSTD-xx

Quality guitar bags for any budget. Made from sturdy nylon material with a 10 mm soft inside padding and heavy duty zippers. Includes a big accessory compartment (perfect size for music books) and two adjustable shoulder straps.

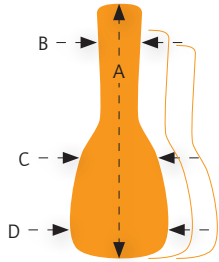

DIMENSIONS

	A	B	C	D
OGBSTD-44	105.0 cm 41.34"	14.0 cm 5.52"	32.0 cm 12.6"	40.0 cm 15.75"
OGBSTD-34	98.0 cm 38.58"	14.0 cm 5.52"	30.0 cm 11.8"	37.0 cm 14.56"
OGBSTD-12	96.0 cm 37.8"	14.0 cm 5.52"	30.0 cm 11.8"	35.0 cm 13.78"

GUITAR BAGS PRO ONB-xx



ONB-xx

Professional classic gig bags made from heavy duty nylon material. Thick padding inside, very wide neck brace with safety straps, heavy duty zippers, wide and comfortable shoulder straps (adjustable), padded handle and two accessory compartments distinguishes these exclusive bags.

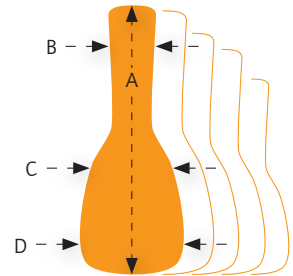

DIMENSIONS

	A	B	C	D
ONB44L full size extra long	105.4 cm 41.5"	14.3 cm 5.63"	31.12 cm 12.25"	40.0 cm 15.75"
ONB44 full size	103.5 cm 40.75"	14.3 cm 5.63"	30.5 cm 12.01"	37.15 cm 14.63"
ONB78 7/8 size	101.0 cm 39.76"	17.0 cm 6.69"	33.5 cm 13.19"	39.0 cm 15.35"
ONB34 three quarter size	94.62 cm 37.25"	14.3 cm 5.63"	26.7 cm 10.51"	35.88 cm 14.13"
ONB12 half size	88.27 cm 34.75"	14.3 cm 5.63"	23.5 cm 9.25"	32.7 cm 12.87"
ONB14 quarter size	76.84 cm 30.25"	14.3 cm 5.63"	21.6 cm 8.5"	28.25 cm 11.12"
ONB-RQ Requinto size	91.0 cm 35.83"	17.5 cm 6.89"	28.5 cm 11.22"	35.0 cm 13.78"

NEW

NEW

BASS BAGS ECONOMY OBBSTD-ACB



OBBSTD-xx

NEW

Quality bass bags for any budget. Made from sturdy nylon material with a 10 mm soft inside padding and heavy duty zippers. Includes a big accessory compartment (perfect size for music books) and two adjustable shoulder straps.

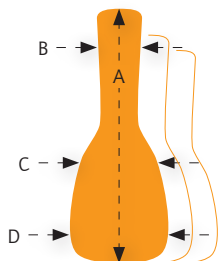

DIMENSIONS

	A	B	C	D
OBBSTD-ACB	126.0 cm 49.61"	16.0 cm 9.3"	36.0 cm 14.17"	48.0 cm 18.9"
Height:	14.5 cm/5.71"			

MANDOLIN & BANJO BAGS PRO ONB-xx



ONB-BJ

ONB-MA

NEW

Professional gig bags made from heavy duty nylon material. Thick padding inside, very wide neck brace with safety straps, heavy duty zippers, wide and comfortable shoulder straps (adjustable), padded handle and two accessory compartments distinguishes these exclusive bags.

DIMENSIONS

	A
ONB-BJ	100.0 cm 39.37"
ONB-MA	74.0 cm 29.13"

UKULELE BAGS ECONOMY OUBSTD-xx

Quality guitar bags for any budget. Made from sturdy nylon material with a 10 mm soft inside padding. Includes an accessory compartment (fits an ORTEGA OPUS portable uke stand!) and two adjustable shoulder straps.



OUBSTD-xx

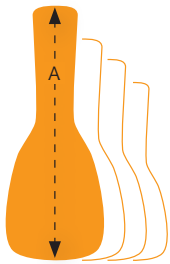

DIMENSIONS

	A (inside)
OUBSTD-SI Sopranino length	54.0 cm 21.26"
OUBSTD-SO soprano length	55.0 cm 21.65"
OUBSTD-CC concert length	62.0 cm 24.41"
OUBSTD-PINE concert length	62.0 cm 24.41"
OUBSTD-TE tenor length	68.0 cm 26.77"
OUBSTD-BA baritone length	78.0 cm 30.71"

UKULELE BAGS PRO OUGB-xx

Professional ukulele gig bags made from heavy duty nylon material. Thick padding inside, heavy duty zippers, padded handle and an accessory compartment distinguishes this exclusive bags.



OUGB-xx



DIMENSIONS

	A (inside)
OUGB-SO soprano length	55.0 cm 21.65"
OUGB-CC concert length	62.0 cm 24.41"
OUGB-TE tenor length	68.0 cm 26.77"
OUGB-BB baritone length	78.0 cm 30.71"



- OACCSTD-DN**
- OCCSTD-34**
- OCCSTD**
- OCCSTD-T**
- OEGCSTD**
- OCCSTD**

CASES ECONOMY

Budget friendly instrument cases in classic black vinyl finish. Flat top, 15 mm padding - covered by "coffee" velvet, accessory compartment, chrome hardware and a strong handle distinguishes these timeless cases.

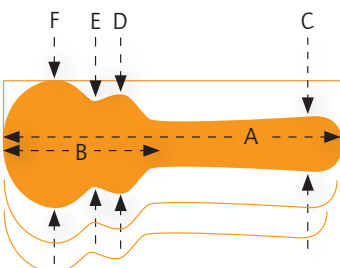

GUITAR CASES

INNER DIMENSIONS

ACOUSTIC	A	B	C	D	E	F	Height
OACCSTD-DN dreadnought	107.5 cm 42.32"	58.0 cm 22.83"	15.5 cm 6.1"	29.5 cm 11.61"	28.0 cm 11.02"	41.0 cm 16.14"	13.5 cm 5.31"
CLASSICAL	A	B	C	D	E	F	Height
OCCSTD-34 classic 3/4 size	98.0 cm 38.58"	47.0 cm 18.50"	12.5 cm 4.92"	25.0 cm 9.84"	23.0 cm 9.06"	35.0 cm 13.78"	11.0 cm 4.33"
OCCSTD regular classic	103.0 cm 40.55"	56.0 cm 22.05"	14.5 cm 5.71"	27.5 cm 10.83"	26.0 cm 10.24"	38.5 cm 15.16"	12.0 cm 4.72"
OCCSTD-T thinline classic	107.0 cm 42.13"	56.0 cm 22.05"	14.5 cm 5.71"	27.5 cm 10.83"	26.0 cm 10.24"	38.5 cm 15.16"	10.5 cm 4.13"
ELECTRIC	A	B	C	D	E	F	Height
OEGCSTD rectangle	105.0 cm 41.34"	50.0 cm 19.68"	-	-	-	33.0 cm 12.99"	9.0 cm 3.54"
OCCSTD single cut	101.0 cm 39.67"	50.0 cm 19.68"	15.0 cm 5.9"	23.0 cm 9.05"	21.0 cm 8.27"	34.0 cm 13.38"	10.0 cm 3.94"



CASES ECONOMY



OABCSTD

OEBCSTD

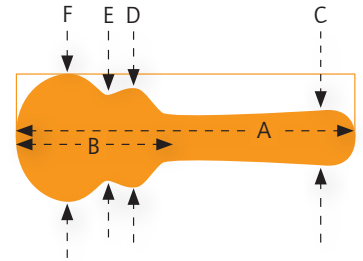

BASS CASE

INNER DIMENSIONS

ACOUSTIC	A	B	C	D	E	F	Height
OABCSTD acoustic bass	127.0 cm 50.0"	58.5 cm 23.03"	16.0 cm 6.3"	32.0 cm 12.6"	29.5 cm 11.61"	43.0 cm 16.93"	13.5 cm 5.31"
ELECTRIC	A	B	C	D	E	F	Height
OEBCSTD electric bass	119.0 cm 46.85"	55.5 cm 21.65"	-	-	-	34.5 cm 13.58"	9.0 cm 3.54"



OBJCSTD

OMCSTD-A

OMCSTD-F

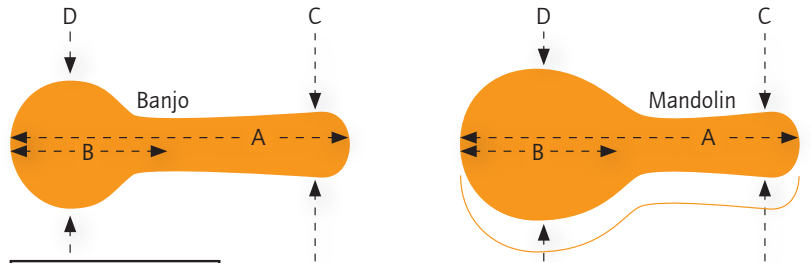

BLUEGRASS CASES

INNER DIMENSIONS

	A	B	C	D	Height
OBJCSTD Banjo regular 5/6 String	103.0 cm 40.55"	44.0 cm 17.32"	14.0 cm 5.51"	34.5 cm 13.58"	12.5 cm 4.92"
OMCSTD-A Mandolin A-style	71.0 cm 27.95"	39.0 cm 15.35"	15.0 cm 5.91"	27.5 cm 10.83"	10.0 cm 3.94"
OMCSTD-F Mandolin F-style	71.0 cm 27.95"	39.0 cm 15.35"	15.0 cm 5.91"	27.5 cm 10.83"	10.0 cm 3.94"



OUCSTD-SO

OUCSTD-CC

OUCSTD-TE

OUCSTD-BA

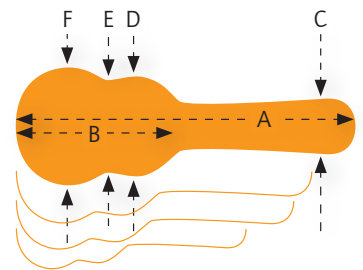

UKULELE CASES

INNER DIMENSIONS

	A	B	C	D	E	F	Height
OUCSTD-SO soprano	55.0 cm 21.65"	29.0 cm 11.42"	12.0 cm 4.72"	14.5 cm 5.71"	14.0 cm 5.51"	17.0 cm 6.69"	8.5 cm 3.35"
OUCSTD-CC concert	66.5 cm 26.18"	32.5 cm 12.8"	13.0 cm 5.12"	14.5 cm 5.71"	14.0 cm 5.51"	19.5 cm 7.68"	9.0 cm 3.54"
OUCSTD-TE tenor	71.0 cm 27.95"	37.0 cm 14.57"	13.5 cm 5.31"	18.5 cm 7.28"	16.5 cm 6.5"	22.0 cm 8.66"	10.0 cm 3.94"
OUCSTD-BA baritone	81.0 cm 31.89"	40.5 cm 15.94"	16.5 cm 6.5"	21.0 cm 8.27"	18.0 cm 7.09"	25.0 cm 9.84"	10.0 cm 3.94"





OCCPRO

OCCPRO-T



Extraordinary deluxe instrument cases in modern brown croco style vinyl finish. Arched case top, 15 mm padding - covered by "coffee crushed" velvet, built-in hygrometer, generous accessory compartment, combination lock, bronze vintage style hardware and a comfortable soft double pipe handle distinguishes these exclusive cases.

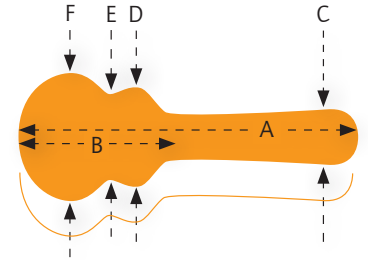

GUITAR CASES		INNER DIMENSIONS						
	A	B	C	D	E	F	Height	
OCCPRO regular classic	103.0 cm 40.55"	56.0 cm 22.05"	14.5 cm 5.71"	27.5 cm 10.83"	26.0 cm 10.24"	38.5 cm 15.16"	12.0 cm 4.72"	
OCCPRO-T thinline classic	107.0 cm 42.13"	56.0 cm 22.05"	14.5 cm 5.71"	27.5 cm 10.83"	26.0 cm 10.24"	38.5 cm 15.16"	10.5 cm 4.13"	

CASES BACK PACK STRAPS



OBPS

ORTEGA BACK PACK STRAP

Designed to carry hard cases like a gig bag.

- Adjustable shoulder straps
- Securely fasten your case with adjustable straps and hard plastic release buckles
- Fits ALL shaped hard cases
- 10 mm soft padding with up to 85 mm wide shoulder pads
- Easy to install and remove - no tools needed!
- Nylon, black



OBPS-DLX

ORTEGA BACK PACK STRAP DELUXE

Designed to carry hard cases like a gig bag. The Ortega Back Pack Strap Deluxe features an ergonomic padded back cushion to relax your back while carrying your case.

- Adjustable extra wide shoulder straps
- Ergonomic padded back cushion
- Securely fasten your case with adjustable straps and hard plastic release buckles
- Fits ALL shaped hard cases
- 10 mm soft padding with up to 85 mm wide shoulder pads
- Easy to install and remove - no tools needed
- Nylon, black



DIGITAL WIRELESS SYSTEMS

DIGITAL WIRELESS SYSTEM ODWS-1



ODWS-1



ODWS-1BK



ODWS-1CAR



ODWS-1MAD



ODWS-1WND

The Ortega Digital Wireless System features 2.4 Ghz digital technology and broadcasts incredible crystal-clear audio quality. Ready to use in seconds the system offers four operating channels (A, B, C, D), power/charge indicator and a rechargeable, built-in battery (+2500 charging cycles). The latency of < 5 ms and a full range frequency coverage of 20 Hz - 20 kHz secures great, detailed and real time sound. The ODWS supports most active & passive systems as well as acoustic piezo devices*.

The ODWS Digital Wireless System:

- 2.4 GHz ISM worldwide
- Up to 30 meters (100 ft.) of range without any dropout**
- 4 channels
- Up to 4 systems simultaneously
- Rubberized SHOCKPROOF housing (ODWS-1 & ODWS-1BK)
- 24 bit/48 kHz uncompressed digital transmission
- Easy to start in seconds – plug & play
- Auto-standby (sleep mode) after 10 seconds when there is no signal
- One transmitter can serve multiple receivers
- Rechargeable via USB (cable included!)
- Up to 5 hours use on a single charge
- Appx. 225° adjustable jack to fit almost every instrument
- 2.4 GHz technology is permission free/approved for use in America (North and South), Europe, Asia and Australia***
- THD + Noise: > 0.05 % (1KHz @ -10dbFS)
- Dynamic Range: > 103 db A weighted
- Operating temperature: -10° to 50° celcius (14° F - 122° F)

Includes:

- 1x Transmitter
- 1x Receiver
- 1x USB double head charger cable

TRANSMITTER || RECEIVER

- ODWS-1** black || orange
- ODWS-1BK** black || black
- ODWS-1CAR** carbon || carbon
- ODWS-1MAD** maple design || maple design
- ODWS-1WND** walnut design || walnut design

* Some high output active systems, especially active acoustic piezos might not match well with 2.4 GHz systems.
 ** Open field, depends on RF environment, reflections, interference and absorption. Keep distance from WIFI router.
 *** Present legislation, please inform yourself about possible changes.



USB double head charger cable included



Plug directly into an amplifier



Plug into a pedal

WIRELESS SYSTEM HOLDER | OWSH



OWSH



Easy to mount Wireless Transmitter Pouch for Instrument Straps.

- Connector Cable included!
- SIGNIFICANTLY REDUCES DIGITAL INTERFERENCE!

Ideal for comfortably and conveniently holding pocket wireless transmitters on performers strap. The pouch secures easily with hook and loop fasteners on almost any type of strap.

- Made with high quality faux leather
- Fits for ORTEGA ODWS-1 systems and many other compact digital wireless systems
- Flexible nylon strips ensure a secure hold
- Fits any strap
- Easy to install with hook and loop fasteners.

EXTENSION CABLE | OWCI



OWCI

Extension cable with angle plug. Great for all side output jacks.

- 2,5 ft (75 cm)
- 1/4" (6.3 mm) jack / 1/4" (6.3 mm) female

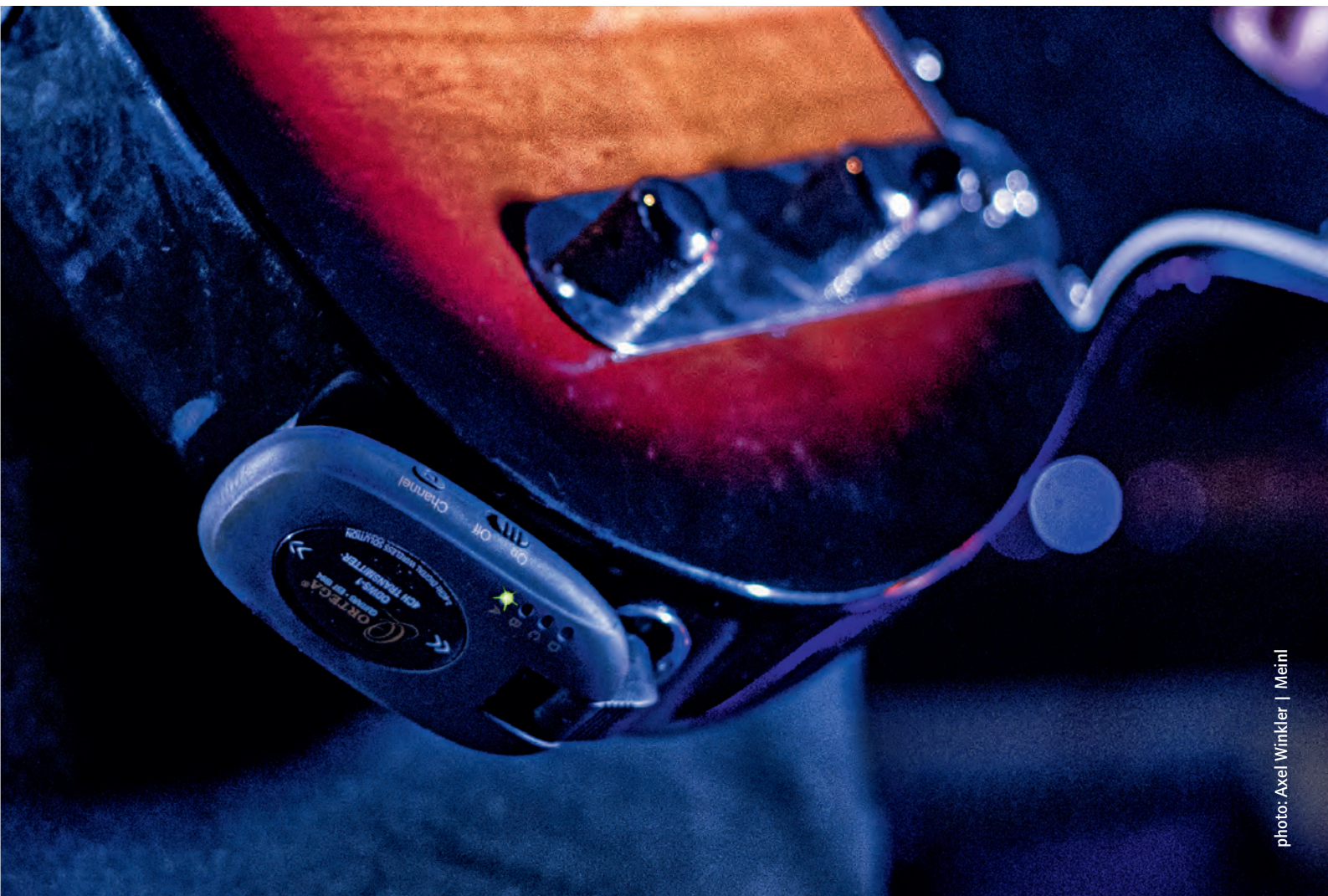



CABLES

INSTRUMENT CABLES - ECONOMY SERIES W/ BRAIDED NYLON JACKET

ORTEGA GUITARS Economy Series Instrument & Patch Cables offer quality design and sound for all live & studio environments. Reliable & durable, our cables are developed to last and deliver the best balance between performance and players equipment.

- Custom designed with an extra thick O.D. (outside diameter) of 8 mm
- Extra thick braided nylon jacket avoids annoying tangles and minimizes handling noise
- 24 Gauge AWG (American Wire Gauge) with 95% OCC copper braided shielding for flexibility and to minimize interference
- High grade industry standard connectors with heat shrunk sleeves for additional strain relief



OECI-xx



OECIS-xx



INSTRUMENT CABLE STRAIGHT/ANGLE

- 1/4" (6.3 mm) jack/jack, braided nylon over PVC, black
- OECI-5** 5 ft (1.5 m), 0.8 q
- OECI-10** 10 ft (3.0 m), 0.8 q
- OECI-15** 15 ft (4.5 m), 0.8 q
- OECI-20** 20 ft (6.0 m), 0.8 q
- OECI-30** 30 ft (9.0 m), 0.8 q

INSTRUMENT CABLE STRAIGHT/STRAIGHT

- 1/4" (6,3 mm) jack/jack, braided nylon over PVC, black
- OECIS-5** 5 ft (1.5 m), 0.8 q
- OECIS-10** 10 ft (3.0 m), 0.8 q
- OECIS-15** 15 ft (4.5 m), 0.8 q
- OECIS-20** 20 ft (6.0 m), 0.8 q
- OECIS-30** 30 ft (9.0 m), 0.8 q

INSTRUMENT CABLES - RETRO SERIES W/ PVC JACKET

ORTEGA GUITARS high performance RETRO Series Instrument Cables offer quality design in the spirit of the 70's legends.

Custom designed with an O.D. of 6.5 mm and 24 AWG (American Wire Gauge) the extra wide coiled RETRO Series cables deliver freedom on stage and great memories.



ORCCI-30xx



ORCCIS-30xx

INSTRUMENT COIL CABLE STRAIGHT/ANGLE



- 1/4" (6.3 mm) jack/jack, PVC jacket, conductive PE shield, black (BK) & white (WH)
- ORCCI-30BK** 30 ft (9.0 m), 0.8 q
- ORCCI-30WH** 30 ft (9.0 m), 0.8 q

INSTRUMENT COIL CABLE STRAIGHT/STRAIGHT



- 1/4" (6,3 mm) jack/jack, PVC jacket, conductive PE shield, black (BK) & white (WH)
- ORCCIS-30BK** 30 ft (9.0 m), 0.8 q
- ORCCIS-30WH** 30 ft (9.0 m), 0.8 q

INSTRUMENT CABLES - TOUR SERIES W/ PVC JACKET

ORTEGA GUITARS high performance TOUR Series Instrument Cables are designed for the rough daily routine of touring. With an 8 mm diameter, these cable offer perfect signal transmission. The electric plated zinc alloy shell equipped connectors are covered with an inner epoxy resin insulation.

For a perfect and noiseless instrument change the connectors are equipped with MUTEPLUGS muting the signal during plugging in and unplugging.

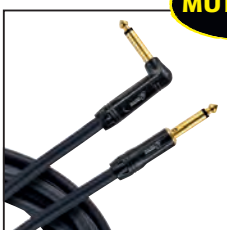

OTCI-xx



OTCIS-xx



INSTRUMENT CABLE MUTEPLUG STRAIGHT/ANGLE

- 1/4" (6.3 mm) MUTEPLUG jack, PVC jacket, conductive PE shield, black
- OTCI-10** 10 ft (3.0 m), 0.8 q
- OTCI-15** 15 ft (4.5 m), 0.8 q
- OTCI-20** 20 ft (6.0 m), 0.8 q
- OTCI-30** 30 ft (9.0 m), 0.8 q

INSTRUMENT CABLE MUTEPLUG STRAIGHT/STRAIGHT

- 1/4" (6.3 mm) MUTEPLUG jack, PVC jacket, conductive PE shield, black
- OTCIS-10** 10 ft (3.0 m), 0.8 q
- OTCIS-15** 15 ft (4.5 m), 0.8 q
- OTCIS-20** 20 ft (6.0 m), 0.8 q
- OTCIS-30** 30 ft (9.0 m), 0.8 q



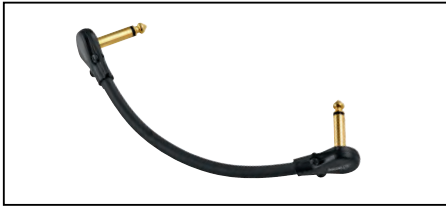

OTCPA-04



PU20-OTCPA-04

PATCH CABLE PANCAKE STYLE

1/4" (6.3 mm) „PANCAKE“ jacks w/gold tip, PVC jacket, conductive PE shield, black

OTCPA-04 0.4 ft (13 cm), 0.65 q

PU20-OTCPA-04 PACKING UNIT of 20x OTCPA-04 incl. **attractive Display Bowl**



OECPA3-06

PATCH CABLE ANGLE/ANGLE

1/4" (6,3 mm) jack/jack, braided nylon over PVC, black

OECPA3-06 0.6 ft (18 cm), 0.8 q, pack of 3

LOUDSPEAKER CABLE - TOUR SERIES

ORTEGA LOUDSPEAKER CABLES are manufactured with the highest grade materials in the industry. The copper wire meets AWG rating specifications. The all-metal, nickel plated classic connectors provide durability and exceptional performance.

LOUDSPEAKER CABLE OTCLS-5JJ



Ortega Tour Series Speaker Cables - The premium connection for your sound.

- 5 feet | 1.5 m length
- True 12AWG (American Wire Gauge) rated
- Professional Quality and Construction
- Extra thick 10.0 mm Durable & Flexible Rubber Jacket
- 2x reuseable Hook and Loop Warp included



OTCLS-5JJ

CABLE TIES PACK OF 10



OCBT-10

Ortega Cable ties keep your cables coiled up and well organized for tidy storage. Works with all instrument, microphone and power cables.

OCBT-10 Cable ties, hook & loop 0.6 x 0.065 ft (18 cm x 2 cm), orange, pack of 10



MICROPHONE CABLES - ECONOMY SERIES W/ BRAIDED NYLON JACKET

ORTEGA GUITARS Economy Series Instrument, Microphone & Patch Cables offer quality design and sound for all live & studio environments. Reliable & durable, our cables are developed to last and deliver the best balance between performance and players' equipment.

- Custom designed with an extra thick O.D. (diameter) of 8 mm
- Extra thick braided nylon jacket avoids annoying tangles and minimizes handling noise
- 24 Gauge AWG (American Wire Gauge) with 95 % OCC copper braided shielding for flexibility and to minimize interference
- High grade industry standard XLR & JACK connectors with heat shrunk sleeves for additional strain relief



OECM-xxJX

MICROPHONE CABLE 1/4" (6.3 mm) JACK/XLR FEMALE

Braided nylon sleeve over PVC jacket, black

OECM-10JX 10 ft (3.0 m), 0.8 q

OECM-20JX 20 ft (6.0 m), 0.8 q

OECM-30JX 30 ft (9.0 m), 0.8 q



OECM-xxXX

MICROPHONE CABLE XLR MALE/XLR FEMALE

Braided nylon sleeve over PVC jacket, black

OECM-10XX 10 ft (3.0 m), 0.8 q

OECM-20XX 20 ft (6.0 m), 0.8 q

OECM-30XX 30 ft (9.0 m), 0.8 q



PICKS

20 ORTEGA PICKS – packing unit



PU20-OGPOR-M

Ortega PU20-OGPOR-M contains 20-piece pack of guitar picks in original Ortega orange featuring a 0.71 mm, medium thickness for great playability. A light “sandy” surface provides a firm comfortable grip.

ORTEGA UKULELE LEATHER PICKS



UKEPICK-ASS

PERFECT FOR ANY NYLON STRING GUITAR, TOO!

Soft and extra large **REAL LEATHER PICKS** – especially designed for ukulele players but also perfect to use with any Nylon String Guitar.

- Warm soft tones with no loss of volume

UKEPICK-ASS Assorted pack of 3 black/white/red

ORTEGA FELT PICKS – SOFT & HARD



OGP-F-S3
OGP-F-H3

Custom designed especially for Ukulele & Nylon String Guitar. Made from high quality compressed synthetic wool, rounded tip, anti-slip “grip hole” – pack of 3

OGP-F-S3 3 mm thickness, **SOFT**
Color: light grey

OGP-F-H3 4 mm thickness, **HARD**
Color: light brown

OGP-V1 – LEATHER & FELT



OGP-V1

Custom designed and perfect for Ukulele, Nylon String Guitar, Bass and many other acoustic instruments.

Variety Pack of 4:

- Leather pick, black
- Leather pick, white
- Felt pick, 3 mm, soft
- Felt pick, 4 mm, hard

ORTEGA PICKS

Guitar picks – Made in Germany. Produced with highest industry standard – pack of 10

OGP-BP-T10

blue pearl, thin

OGP-BP-M10

blue pearl, medium

OGP-BP-H10

blue pearl, heavy

OGP-WP-T10

white pearl, thin

OGP-WP-M10

white pearl, medium

OGP-WP-H10

white pearl, heavy

OGP-TO-T10

tortoise, thin

OGP-TO-M10

tortoise, medium

OGP-TO-H10

tortoise, heavy



OGP-BP **OGP-WP** **OGP-TO**



ORTEGA WOODEN PICKS – CURVED

STANDARD, SHARP TIP, CURVED THUMP GRIP – HANDMADE FROM REAL WOOD

2.5 mm thickness.

Made from high quality real wood, sharp tip.

OGPW-OV2 olive wood, pack of 2

OGPW-PD2 padouk wood, pack of 2

OGPW-SW2 sandalwood, pack of 2

OGPW-CH2 chacate wood, pack of 2

OGPW-MIX4 1x olive, 1x padouk, 1x sandal, 1x chacate – pack of 4



OGPW-OV2
OGPW-PD2

OGPW-SW2
OGPW-CH2

OGPW-MIX4



OGPWXLF-OV2
OGPWXLF-PD2
OGPWXLF-SW2
OGPWXLF-CH2



OGPWXLF-MIX4

ORTEGA WOODEN PICKS – FLAT

TRIANGLE XL, SHARP TIP, FLAT – HANDMADE FROM REAL WOOD

2.0 mm thickness.

Made from high quality real wood, sharp tip.

OGPWXLF-OV2 olive wood, pack of 2

OGPWXLF-PD2 padouk wood, pack of 2

OGPWXLF-SW2 sandalwood, pack of 2

OGPWXLF-CH2 chacate wood, pack of 2

OGPWXLF-MIX4 1x olive, 1x padouk, 1x sandal, 1x chacate – pack of 4

FLEX TECH PICKS – SOFT & HARD



OGP-FTS
OGP-FTH

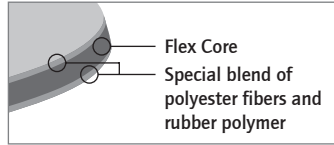

IDEAL FOR UKULELE & NYLON STRING GUITARS

Ortega Guitars FLEX TECH PICKS are handmade in the USA from a flexible composite felt which provides unrivaled tone and performance. Ideal for Ukulele, Nylon String Guitars, Acoustic Bases and many other stringed instruments.

OGP-FTS

SOFT, FLEX TECH with FLEX CORE TECHNOLOGY, 2.5 mm/0.984" white, pack of 4

OGP-FTH

HARD, FLEX TECH with FLEX CORE TECHNOLOGY, 3.8 mm/1.496" black, pack of 4

S-TECH PICKS



OGPST12-050
OGPST12-060
OGPST12-073



OGPST12-088
OGPST12-100
OGPST12-120



OGPSD-216

PACK OF 12 PICKS

Made in the USA, Ortega Guitars S-Tech picks combine the highest quality materials with traditional craftsmanship and modern production techniques to produce a professional guitar pick with exceptional durability, a grip friendly granular surface, and dynamic response – pack of 12.

OGPST12-050

pink, 0.50 mm

OGPST12-088

blue, 0.88 mm

OGPST12-060

green, 0.60 mm

OGPST12-100

red, 1.00 mm

OGPST12-073

sand, 0.73 mm

OGPST12-120

black, 1.20 mm

DISPLAY WITH 216 PICKS

Attractive, 100% recyclable hard paper sales display with 216 x ORTEGA S-TECH PICKS (pack of 36 of each thickness) included.

OGPSD-216

REFILL PACKS

Perfect to refill the OGPSD216 sales box or have a safety stock. Each refill pack contains 36 picks.

OGPST36-050

pink, 0.50 mm

OGPST36-060

green, 0.60 mm

OGPST36-073

sand, 0.73 mm

OGPST36-088

blue, 0.88 mm

OGPST36-100

red, 1.00 mm

OGPST36-120

black, 1.20 mm

WOOD SLIDES

European Birch European Cherry



NEW

DIMENSIONS

	S	M	L	XL
LENGTH	58.0 mm 2.28"	60.0 mm 2.36"	60.0 mm 2.36"	60.0 mm 2.36"
DIAMETER	18.0 mm 0.71"	19.0 mm 0.75"	21.0 mm 0.83"	22.0 mm 0.87"

WOOD SLIDES

The Wood Slide combines the sound of a traditional bottleneck slide with the characteristics of a wooden product. The slide isn't as heavy as a brass slide, and it has by far the warmest sound of any slide you'll ever hear. Available in 4 sizes (Small, Medium, Large, and X-Large) you are sure to find the perfect fit.

OWS-S, small

OWS-M, medium

OWS-L, large

OWS-XL, x-large





TUNERS

NEW

easy tune!



flat

in tune

sharp

OET-BK

CLIP ON TUNER OET-BK

Multi-mode calibratable clip-on tuner for chromatic, guitar, bass, ukulele & violin.

- Full color LED display
- Full flexible rotatable head
- Extra large screen
- Calibrates 430-450 Hz
- Very light weight
- Extra sensitive clamp sensor

Color: Black

Automatic note detection: (C, G, B, U, V Mode)

Chromatic: C-C#-D-D#-E-F-F#-G-G#-A-A#-B-C

Guitar: 6E-5A-4D-3G-2B-1E

Bass: 5B-4E-3A-2D-1G

Violin: 4G-3D-2A-1E

Ukulele (C): 4G-3C-2E-1A

CLIP-ON TUNER BLACK

Easy tune

- Incl. battery (coin cell, TYPE CR2032)

OET-BK

DISPLAY WITH 10 CLIP-ON TUNER

Attractive recycled hard paper sales display with 10x OET-BK clip-on tuner included.

OETSD-10BK



C (chromatic)



G (guitar)



B (bass)



V (violin)



U (ukulele)



OCAT-2BK



CLIP ON TUNER OCAT-2BK

The OCAT-2BK is a tuner and metronome, all in one. Mic and vibration sensor built-in to use anywhere. Fully chromatic and calibratable (410-490 Hz). Flat tuning up to 4 semitones. Built-in VISUAL metronome.

- Incl. battery (coin cell, TYPE CR2032)



OCST-1BK

MULTI-MODE SOUNDHOLE TUNER OCST-1BK

MULTI-MODE FUNCTIONALITY FOR CHROMATIC, GUITAR, BASS & UKULELE



Blue backlight - not in tune



Green backlight - in tune

The OCST-1BK multi-mode soundhole tuner was designed specifically with acoustic instruments in mind:

- Discreet and easy to install/remove
- Piezo equipped soundhole clip
- Quick change mode selector
- Easy-to-read 2-color display (blue/green)
- In tune - backlight illuminates fully green!
- Rubberized shockproof housing
- Incl. battery (coin cell, TYPE CR2032)

LOVE POTION

Give your stringed instrument some love and care! With our Ortega Love Potion guitar, string, and fretboard care, we can offer you the all-round package for your beloved instrument. All three care products are made in Germany and contain jojoba oil, which isn't only a sustainable natural product, it's also perfectly suitable for cleaning and lubricating wooden surfaces.



VEGAN



OLP-PACK

OLP-PACK

Complete cleaning kit for your guitar's body, fretboard, and strings. The Ortega Love Potion Pack consists of **1x OLP-GTR**, **1x OLP-STR**, and **1x OLP-FB** and offers the perfect bundle for your instrument.

- Ortega Love Potion Guitar Polish gives your guitar a brilliant shine while cleaning it. With Jojoba Oil.
- Ortega Love Potion String Conditioner keeps your strings clean and makes them last longer
- Ortega Love Potion Fretboard cleans and conditions your fretboard

OLP-FB



OLP-FB

Unfinished fretboards are exposed to temperature/humidity changes and therefore need special maintenance. The **OLP-FB** comes in a 20 ml bottle and is perfect for lubricating and cleaning the fretboard of your instrument. The Fretboard Care is a vegan product!

- Ortega Love Potion Fretboard cleans and conditions your fretboard
- VEGAN and with high quality JOJOBA oil
- 20 ml (0.7 fluid oz)
- Made in Germany



OLP-GTR

OLP-GTR

Stains and sweat which occur from playing your instrument can easily be cleaned with this liquid! The **OLP-GTR** comes in a 150 ml spray bottle for an easy application. The Guitar Care is a vegan product!

- Ortega Love Potion Guitar Polish gives your guitar a brilliant shine while cleaning it. With Jojoba Oil.
- VEGAN and with high quality JOJOBA oil
- 150 ml (5.1 fluid oz)
- Made in Germany



OLP-STR

OLP-STR

Guitar strings often lack care and tend to lose their clear sound due to sweat and dirt, which ultimately leads to corrosion.

You can clean your strings, protect them from corrosion, and preserve their bright tone by using the **OLP-STR**. The **OLP-STR** comes in a 150ml spray bottle for an easy application.

- Ortega Love Potion String Conditioner keeps your strings clean and makes them last longer
- High quality LANOLIN (anti rust) and JOJOBA oil
- 150 ml (5.1 fluid oz)
- Made in Germany

Corrosion Protection Formula



OLEM

FRETBOARD OIL OLEM

Lemon oil – cleaning, conditioning & restoring

The original Ortega Guitars Lemon Oil is perfect to remove dirt, wax and grease from dark wooden surfaces incl. unfinished fretboards.*

60 ml (2.1 fluid oz)

* For best results we recommend you use original Ortega polish cloth OPC-GR/LG, OPC-LY/LB or OPC-XXL

NEW

OIWM



Multipurpose neck support



Professional non-slip surface instrument work mat.

- Multi-purpose neck support included, suitable for most stringed instruments
- Textured non-stick surface prevents from sliding on your workbench
- Superior quality soft foam, protects your instrument from scratches
- Size mat: 103 cm (40.55") x 43,5 cm (17.13")
- For finish safety – temporary use only

POLISH CLOTH



OPC-LY/LB
PACK OF 2

OPC-GR/LG
PACK OF 2

Professional, extra soft microfiber polishing/cleaning cloth with serrated edge. Features embossed Ortega logo.

OPC-GR/LG – pack of 2! (green/light grey)

Dimensions: 29 cm x 24 cm (11.5" x 9.5")

OPC-LY/LB – pack of 2! (light yellow/light brown)

Dimensions: 29 cm x 24 cm (11.5" x 9.5")

OPC-XXL – extra large size (light yellow)

Dimensions: 50 cm x 40 cm

(19.70" x 15.75")



OPC-XXL



CARE

PROTECTION FOILS



OERP

**NO GLUE!
ELECTROSTATIC
FEATURES**

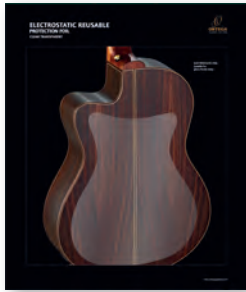

OBCF



OERP



OBCF



OPG-FLAM1

**PERMANENT
GLUE!**



OERP-FLAM1

**NO GLUE!
ELECTROSTATIC
FEATURES**

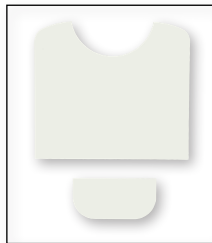

OPG-FLAM2

**PERMANENT
GLUE!**



OERP-FLAM2

**NO GLUE!
ELECTROSTATIC
FEATURES**



Electrostatic reusable foils. The perfect protection against dings & scratches. Clear transparent. To use on gloss finishes only. Removable any time!

OERP

Pickguard for top, transparent

OBCF

Back cover foil, transparent

Transparent scratch plates for acoustic guitars protect the top surface against scratches and dings. Clear transparent foil for Flamenco Style playing.

OPG-FLAM1

Permanent glue on **FULL TOP** foil set.

Usable on gloss & satin finishes. Self-gluing foil for permanent installation. String change protection foil included.

OERP-FLAM1

Reusable electrostatic **FULL TOP** foil set.

Usable on gloss finishes only. Holds with electrostatic features. String change protection foil included.

OPG-FLAM2

Permanent glue on **DIVIDED** foil set.

Usable on gloss & satin finishes. Self-gluing foil for permanent installation. String change protection foil included.

OERP-FLAM2

Reusable electrostatic **DIVIDED** foil set.

Usable on gloss finishes only. Holds with electrostatic features. String change protection foil included.

WOODEN UKULELE PICKGUARDS



**OWPSC-EB
OWPTB-EB**



**OWPSC-FMA
OWPTB-FMA**



**OWPSC-WN
OWPTB-WN**



Choose your personal style

EBONY - FLAMED MAPLE - WALNUT

Made from REAL wood, the Ortega ukulele pickguards light up your instrument and makes your ukulele stand out with extra flair. Easy to put on with already installed adhesive foil. Shaped for Soprano, Concert, Tenor & Baritone size.

SOPRANO & CONCERT soundhole diameter appx. 55 mm

OWPSC-EB EBONY

OWPSC-FMA FLAMED MAPLE

OWPSC-WN WALNUT

TENOR & BARITONE soundhole diameter appx. 58 mm

OWPTB-EB EBONY

OWPTB-FMA FLAMED MAPLE

OWPTB-WN WALNUT

HUMIDIFIERS



HUMIGT-BK



HUMIGT-SV



HUMIUUK-BK



HUMIUUK-SV



Suspend between the strings - no body touch

Humidifying wooden acoustic instruments is the most underrated topic, but the lack of humidification is the number one cause of repairs. The ORTEGA humidifiers are the easiest and simplest way to maintain your instruments in best humidity condition.

- Ortega humidifiers suspend between the strings and never touch any part of the instruments body
- Easy to refill sponge style system
- Non-drip design - releases moisture (if needed for instrument) evenly and slowly to maintain the proper humidity level
- Includes a syringe for water

Soundhole humidifier for ACOUSTIC GUITAR

HUMIGT-BK BLACK

HUMIGT-SV SILVER

Soundhole humidifier for UKULELE, 1/4 & 1/2 size instruments

HUMIUUK-BK BLACK

HUMIUUK-SV SILVER

HUMIBUSTER



HUMIBUSTER100
HUMIBUSTER80



Includes a syringe for water refill

Feedback killer & Humidifying system. Permanent feedback cover for acoustic instruments with the additional function of a humidifying system. Equipped with a sponge and pores, the system maintains the relative humidity of your instrument and protects the wood from drying out.

HUMIBUSTER100

100 mm (4") diameter, fits most acoustic guitars and acoustic basses

HUMIBUSTER80

85 mm (3.35") diameter, fits most classical guitars

ELIMINATOR



ELIMINATOR100
ELIMINATOR86



FITS ALMOST ALL ACOUSTIC INSTRUMENTS!

Feedback Eliminator/ Soundhole Cover

Simply place the ELIMINATOR into your acoustic's soundhole and start your feedback-free performance. Designed to play at a far greater volume on stage without the risk of unwanted howling or feedback. Safe for the instruments' finish due to its soft rubber.

ELIMINATOR100

100 mm (4") diameter, fits most steel strings & acoustic basses

ELIMINATOR86

86 mm (3.38") diameter, fits most nylon & classical guitars

FINGER TRAINER



FEX4



FEX5



Only a few minutes for best results



Lockable pistons for more exercise possibilities



The original Ortega Guitars FEX4 & FEX5 are advanced pocked-sized, light weight training tools for different needs. FEX4 & FEX5 helps you to build-up strength for the entire hand and forearm.

Adjustable tension for each finger

FEX4 3-7 lbs (appx. 1.3-3.2 kg), 4 pistons

FEX5 3-8.5 lbs (appx. 1.3-3.9 kg), 5 lockable pistons for more training possibilities.

Train and maintain strength for your fingers, palm and forearms, supports reaction speed, flexibility and other high difficult action training.

PERFECT PRE-GIG WARM-UP TOOL, PRE-CLIMBING EXERCISE TOOL /SPORTS SUPPORT & MEDICAL REHABILITATION TOOL.*

FEX4 individual adjustable tension for 4 available pistons

FEX5 individual adjustable tension for 5 available pistons

* Ask your doctor IN ADVANCE for medical rehabilitation use.



USEFUL HELPERS

3 HEAD STRING WINDER & CUTTER



UKULELE

GUITAR

BASS



OSWC-3H

A practical tool to make changing strings effortless. The Ortega Guitars 3 Head Multi-tool is a 3-in-1 tool for ukulele, guitar and bass maintenance: peg winder, bridge pin puller, and string cutter.

The OSWC-3H comes with 3 interchangeable heads for ukulele, guitar and bass. Change the strings on almost any instrument with only one tool. Made of high-quality Japanese steel for highest durability.

STRING CUTTER

Made out of hardened JAPANESE STEEL the OSWC-3H provides superior strength and long-lasting durability and cuts the wire with precision.

PIN PULLER

Quick and easy string changes are guaranteed with the built-in bridge pin puller. The wide contact surface of the bridge-pin puller helps to better protect your bridge from marks.

STRING WINDER

The OSWC-3H comes with 3 interchangeable heads for ukulele, guitar and bass – the perfect fit for all your stringed instruments.



VE40-OSW-STD



OSW-STD



OSW-DLX-TBK



OSW-DLX-TBL



OSW-DLX-TYE



OSW-DLX-TCL

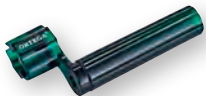

OSW-DLX-TGR



OSW-DLX-TOR



OSW-DLX-TRD

STRING WINDER

String replacement in a few seconds with these classic string winders. The notched head removes bridge pins quickly and safely.

The deluxe version offers additionally a perfectly shaped head for standard and smaller guitar/ukulele machine head knobs and is available in 7 transparent colors.

String Winder Standard:

OSW-STD

Classic string winder, single, orange/black

VE40-OSW-STD

Useful display box – filled with 40x OSW-STD, orange/black

String Winder Deluxe:

OSW-DLX-TBK transparent black

OSW-DLX-TBL transparent blue

OSW-DLX-TYE transparent yellow

OSW-DLX-TCL transparent clear

OSW-DLX-TGR transparent green

OSW-DLX-TOR transparent orange

OSW-DLX-TRD transparent red

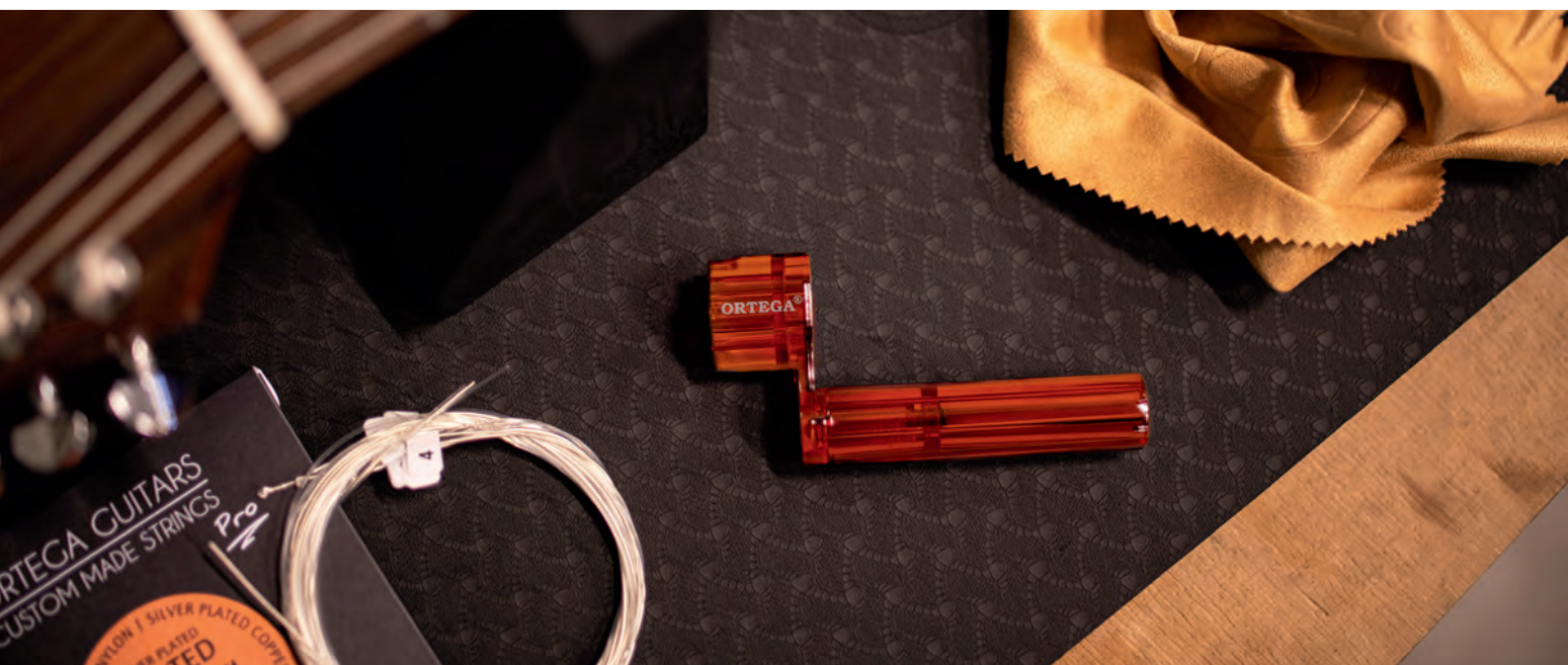

ACOUSTIC & NYLON STRING GUITAR SYSTEMS



MagusGO

Active output jack w/ soundhole control preamp system*

- No need to make a side cut, easy to install
- Powered by 9V battery
- Setup with VOLUME and TONE control (designed for inner soundhole attachment)
- Includes piezo pickup (guitar), battery pocket and cable clamp



MagusPRO/G

Professional side mount onboard active preamp system*

- Built-in tuner (mutes output signal when in use)
- 2 color display
- Seamless, separate VOLUME control
- 3 band EQ featuring single BASS, MIDDLE & TREBLE controls
- Phase turn button
- Powered by 9V battery
- Separate battery compartment with output jack
- Includes piezo pickup (guitar), output/battery compartment device and cable clamp

ACOUSTIC BASS SYSTEM



MagusPRO/B

Professional side mount onboard active preamp system*

- Built-in tuner (mutes output signal when in use)
- 2 color display
- Seamless, separate VOLUME control
- 3 band EQ featuring single BASS, MIDDLE & TREBLE controls
- Phase turn button
- Powered by 9V battery
- Separate battery compartment with output jack
- Includes piezo pickup (bass), output/battery compartment device and cable clamp

UKULELE SYSTEMS



MagusUkeGO

Active output jack w/ soundhole control preamp system*

- No need to make a side cut, easy to install
- Powered by 9V battery
- Setup with VOLUME and TONE control (designed for inner soundhole attachment)
- Includes a flexible pickup, battery pocket and cable clamp



MagusUke

Professional side mount onboard active preamp system*

- Built-in tuner (mutes output signal when in use)
- 2 color display
- TONE control & VOLUME control, FREQUENCY control
- Easy to reach battery compartment
- Uses 2x CR2032 coin cells (we recommend Ortega OER-CR2032/2)
- Includes piezo pickup (ukulele), output jack and cable clamp



MagusUkePRO

Professional side mount onboard active preamp system*

- Built-in tuner (mutes output signal when in use)
- 2 color display
- 3 band EQ featuring single BASS, MIDDLE & TREBLE controls
- Separate battery compartment with output jack
- Uses 2x CR2032 coin cells (we recommend Ortega OER-CR2032/2)
- Includes piezo pickup (ukulele), output/battery compartment device and cable clamp

*To get the best results and to avoid irreparable damage to your instrument please consult a specialized guitar technician for proper installation.



USEFUL HELPERS, CABLES & POWER

DC POWER SPLITTER CABLES



ODC4



ODC6



ODC8

The Ortega ODC4/ODC6/ODC8 are perfect to use with 9V & 18V power supplies. Feeds 4, 6 or 8 devices simultaneously.

ODC4 4head version,
1.40 m/4.6 ft cable length

ODC6 6head version,
2.00 m/6.5 ft cable length

ODC8 8head version,
2.70 m/8.9 ft cable length



OPS9500EU
(most European countries)



OPS9500US
(USA & Canada)



OPS9500JP
(Japan)



OPS9500UK
(Great Britain)

**CABLE LENGTH
OF 3 METERS/9.8 FEET!**

POWER SUPPLY

The **OPS9500** power supply series is intended for use with any effect pedals (analog or digital) requiring 9V and good for up to 500mA.

Special feature:

Cable length of 3 meters /9.8 feet!

- INPUT POWER 100-240 VAC, 50/60 Hz
- OUTPUT POWER 9V DC/500 mA

Ortega power supplies are CE (EUROPE) & UL/class6 (USA) & PSE (Japan) tested and certified.

ORTEGA MUSIC LIGHTS

CLIP ON LED MUSIC LIGHTS

Perfect for travel, music stand lighting, desk and computer or reading.

- Strong and bright LEDs (4/each head)
- Rechargeable via USB!
- Two settings - bright (100%) & dim (50%)
- Adjustable gooseneck(s) for optimal lighting
- Easy to use, strong clamp for mounting
- Easy to install and remove - no tools needed!
- USB charger cable included!

OML-S: SINGLE neck - 8h+ on a single charge

OML-D: DOUBLE neck - 6h+ on a single charge



OML-S



OML-D

**RECHARGEABLE!
NO MORE BATTERIES -
LESS WEIGHT!**

BATTERIES OER-CR2032/2

2 pack of 3V coin cell batteries,
Type CR2032

(recommended for all Ortega
MagusUke and MagusUkePRO pre-
amps and tuners)



OER-CR2032/2



Type CR2032

STRAP LOCKS, PINS & TUNING MACHINES

STRAP LOCK



OSLOPRO-CR

OSLOPRO-GB

OSLOPRO-GO

2 Instruments – only one system. Safely connects your guitar/bass strap with two of your instruments. Includes 1 pair of strap locks with washers, nuts & 2 sets of strap buttons with installation screws.

OSLOPRO-CR Chrome, incl. FREE 2nd pair of screws/pins

OSLOPRO-GB

Gloss black incl. FREE 2nd pair of screws/pins

OSLOPRO-GO Gold, incl. FREE 2nd pair of screws/pins

STRAP PINS



OSTP2-GO

OSTP2-BK

OSTP2-CR

ORTEGA strap pin (pair), incl. washer & screw

OSTP2-GO gold

OSTP2-BK black

OSTP2-CR chrome

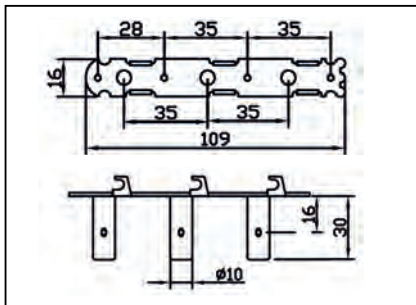

TUNING MACHINES GUITAR



OTM-STUDENT

OTM-STUDENT

RATIO: 14:1

3+3 tuning machine set with chrome plated baseplate, black nylon rollers and black pearl-style buttons.

Original part of the Ortega Student Series.

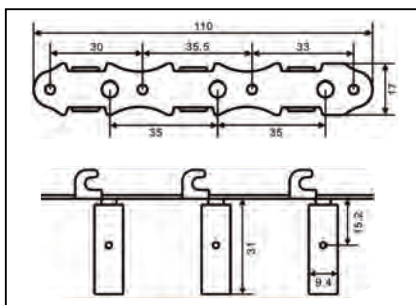

TUNING MACHINES GUITAR



OTM-FAMILYNT

OTM-FAMILYNT

RATIO: 14:1

3+3 tuning machine set with chrome plated baseplate, white nylon rollers and white pearl-style buttons.

Original part of the Family Series - natural.



OTM-FAMILYBK

OTM-FAMILYPRO

OTM-FAMILYBK

RATIO: 14:1

3+3 tuning machine set with golden baseplate, black nylon rollers and black pearl-style buttons.

Original part of the Family Series (black / R221BK).

OTM-FAMILYPRO

RATIO: 14:1

3+3 tuning machine set with golden baseplate, white nylon rollers and white pearl-style buttons.

Original part of the Family Pro Series.

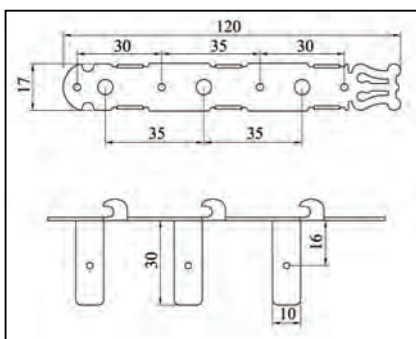

TUNING MACHINES GUITAR



OTMSTD-GOWH

OTMSTD-GOWH

RATIO: 14:1

Golden lyra-design tuning machines with white nylon rollers and white pearl buttons



TUNING MACHINES

TUNING MACHINES GUITAR

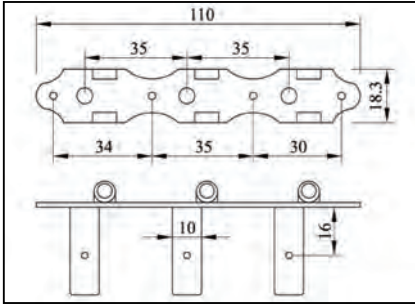

OTMDLX-BKBK

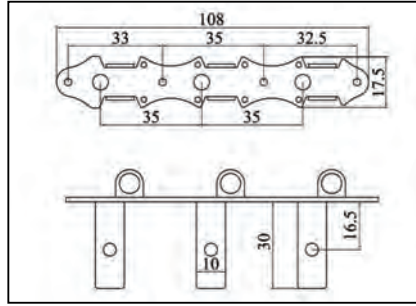

OTMDLX-GOBK

OTMDLX-GOBK

RATIO: 14:1

Golden baseplate tuning machines with black nylon rollers and black ebony-style buttons

OTMDLX-BKBK

RATIO: 14:1

Black baseplate tuning machines with black nylon rollers and black ebony-style buttons

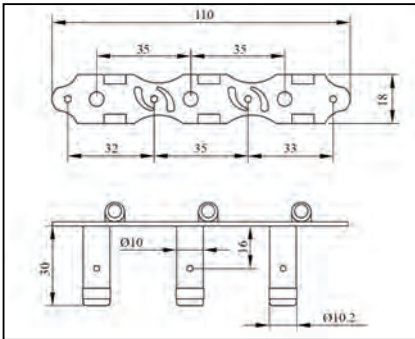

OTMPRIVATE

TUNING MACHINES GUITAR

OTMPRIVATE

RATIO: 18:1

Brushed brass baseplate tuning machines with plated steel worm shafts, black nylon rollers and black ebony-style buttons

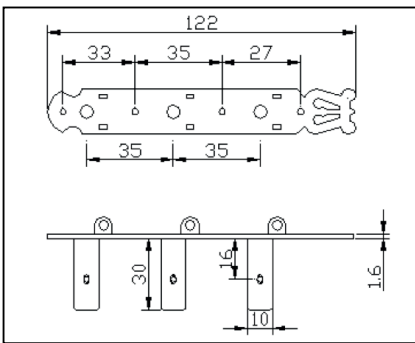

OTMPREMIUM

TUNING MACHINES GUITAR

OTMPREMIUM

RATIO: 18:1

Brushed brass lyra-design baseplate tuning machines with black plated steel worm shafts, black nylon rollers, pearl inlays and black acrylic-style buttons.

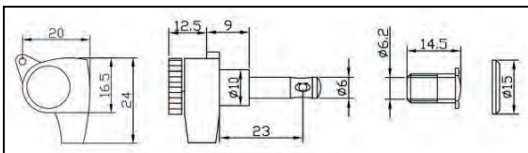

OTMLOCK6L-GB



OTMLOCK6L-GO



OTMLOCK6L-CR

TUNING MACHINES GUITAR

RATIO 18:1

6 in-line locking tuning machine set with (plated) housing and buttons.

OTMLOCK6L-CR chrome

OTMLOCK6L-GB gloss black

OTMLOCK6L-GO gold

RATIO 18:1

3+3 locking tuning machine set with (plated) housing and buttons.

OTMLOCK33-CR chrome

OTMLOCK33-GB gloss black

OTMLOCK33-GO gold



OTMLOCK33-GB



OTMLOCK33-GO



OTMLOCK33-CR

TUNING MACHINES GUITAR

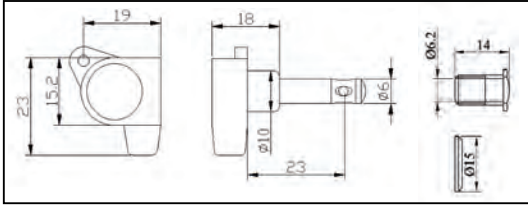

OTMEG33-CR



OTMEG33-GB



OTMEG33-GO



OTMEG6L-CR



OTMEG6L-GB



OTMEG6L-GO

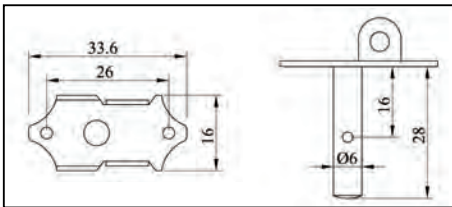

OTMVG-BS

RATIO 14:1

3+3 die-cast tuning machine set with (plated) housing and black buttons.

OTMEG33-CR
chrome

OTMEG33-GB
gloss black

OTMEG33-GO
gold

RATIO 14:1

6 in-line die-cast tuning machine set with (plated) housing and black buttons.

OTMEG6L-CR
chrome

OTMEG6L-GB
gloss black

OTMEG6L-GO
gold

RATIO 16:1

Open-gear tuning machine set with antique brass satin finish and crème buttons.

OTMVG-BS

TUNING MACHINES UKULELE

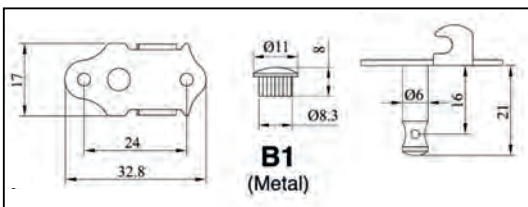

OTMUKOG-CR



OTMUKOG-GO

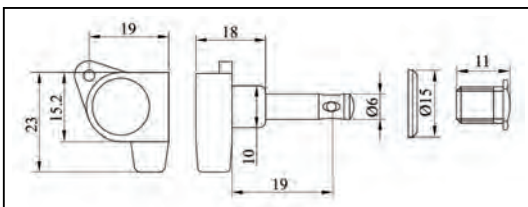

OTMUKDC-CR



OTMUKDC-GB



OTMUKDC-GO



OTMUKSTD-CR

RATIO 14:1

Open-gear ukulele tuning machine set with baseplate and black buttons.

OTMUKOG-CR
nickel

OTMUKOG-GO
gold

RATIO 14:1

Die-cast ukulele tuning machine set with base plate and black buttons.

OTMUKDC-CR
chrome

OTMUKDC-GB
gloss black

OTMUKDC-GO
gold

RATIO 14:1

Economic die-cast ukulele tuning machine set with chrome plated housing and black buttons.

OTMUKSTD-CR



TUNING MACHINES

TUNING MACHINES UKEBASS

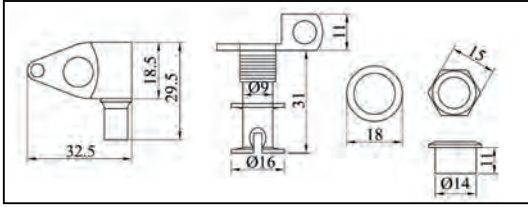

OTMUB-GB

RATIO 24:1

2+2 Ukebass open-gear tuning machine set with black baseplate and buttons.

OTMUB-GB

Ukulele bass, open gear, gloss black

TUNING MACHINES BASS

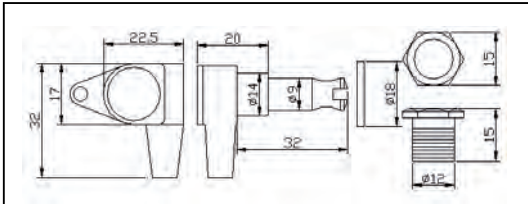

OTMEB4L-CR

RATIO 18:1

4 in-line die-cast tuning machine set for acoustic or electric bass with (plated) housing and buttons.

OTMEB4L-CR chrome

OTMEB4L-GB gloss black

OTMEB4L-GO gold

RATIO 18:1

2+2 die-cast tuning machine set for acoustic or electric bass with (plated) housing and buttons.

OTMEB22-CR chrome

OTMEB22-GB gloss black

OTMEB22-GO gold



OTMEB4L-GB



OTMEB4L-GO



OTMEB22-CR



OTMEB22-GB



OTMEB22-GO

TUNING MACHINES MANDOLINE

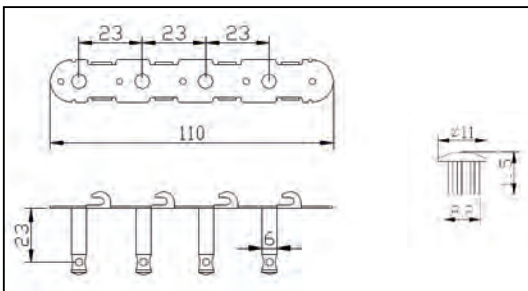

OTMMASTD-GO

RATIO 14:1

4 in-line traditional a-style mandolin tuning machines with baseplate, rollers and buttons.

OTMMASTD-CR chrome

OTMMASTD-GO gold

RATIO 14:1

4 in-line deluxe a-style mandolin tuning machines with baseplate, rollers and buttons.

OTMMADLX-CR chrome

OTMMADLX-GO gold

RATIO 14:1

4 in-line standard f-style mandolin tuning machines with baseplate, rollers and white buttons.

OTMMAPREM-CR chrome

OTMMAPREM-GO gold



OTMMASTD-CR



OTMMADLX-GO



OTMMADLX-CR



OTMMAPREM-CR



OTMMAPREM-GO



2022 LEFT HANDED

#OrtegaLovesLefties

ORTEGA®
GUITARS • EST 1994



FULL LINE
PLEASE TURN OVER





ORTEGA LOVES LEFTIES!

As a left-handed person, you do not need us to tell you how difficult it is to find a stringed instrument with the exact features, fit, and feel you are looking for.

At Ortega Guitars, we understand this challenge, which is why we offer one of the widest selections of left-handed stringed instruments on the market.

In this catalog, you will find **60 models** of guitars, ukuleles, acoustic basses, mandolins, and banjos specifically designed for the wide variety of left-handed musicians out there.

With our broad selection of sizes, colors, neck widths and configurations, you are sure to find the perfect instrument for your needs, **without** the typical "lefty upcharge"!

#OrtegaLovesLefties



2022 LEFT-HANDED CATALOG

INDEX



NYLON STRING GUITARS	4	Keiki® UKULELES	14
Traditional Series	5	K1 Series	14
Performer Series	5	K2 Series	15
Signature Series	6	K3 Series	15
Family Series Pro	7		
Family Series	8	ACOUSTIC BASSES	16
Student Series	8	Deep Series	16
ORTEGA® UKULELES	10	THE PRIVATE ROOM	16
Bonfire Series	10	Striped Suite	16
Earth Series	11		
Horizon Series	11	MANDOLINS & BANJOS	16
Timber Series	12	Mandolins	16
Lizard Series	13	Banjoes	17
Banjolele Series	13		
		ACCESSORIES	17
UKEBASSES	13	Soft cases	17
Lizard Series	13		



www.ortegaguitars.com

GLOBAL HEADQUARTERS
Ortega
Musik-Meinel-Str. 1
91468 Gutenstetten
Germany

US HEADQUARTERS
Meinl USA L.C.
Ortega
3427 Ambrose Avenue
Nashville, TN 37207
USA



info@ortegaguitars.com

Ortega Imprint

Additional changes without notice possible. If necessary – dealer/distributor contact is recommended for detailed information.

Not responsible for typographic errors. No part of this brochure may be reprinted, reproduced or included in any online service or in any other form, in whole or in part, without the prior permission of Ortega. Specifications are subject to change without notice.

Content & Direction:

Bastian Krämer & Ortega Guitars team
Germany/USA – ortegaguitars.com

Concept, Design & Realization:

Werner Stubenvoll & zeitstopp team – zeitstopp.com

Photography and Image Processing:

Christian Habermeier, Sebastian Jäger – studio waldeck
Danny Lucenara – ortegaguitars.com
Yannick Steinicke – ortegaguitars.com

Stock footage: istockphoto.com

© 2022 – Ortega is a registered brand of
Roland Meinl Musikinstrumente GmbH & Co.KG

Photo credits covers:

Full Line
Banjo: Tim Herbig | Photo: Franz Wüstenberg
Mandolin: Lea Randella | Photo: Maria Athens
Bass: Samuel G. Mpungu | Photo: Danny Lucenara
HYDRA: RJ Ronquillo | Photo: Kelli Dirks
Left Handed
Guitar: Steffi List | Photo: Hendrik Holnäck

ORT-CATALOG22



8 42960 18403 7

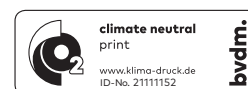

ORT-CATALOG22.10
Printed in Germany



NYLON STRING GUITARS



NYLON STRING GUITARS OPTIONS

SCALES & SIZES

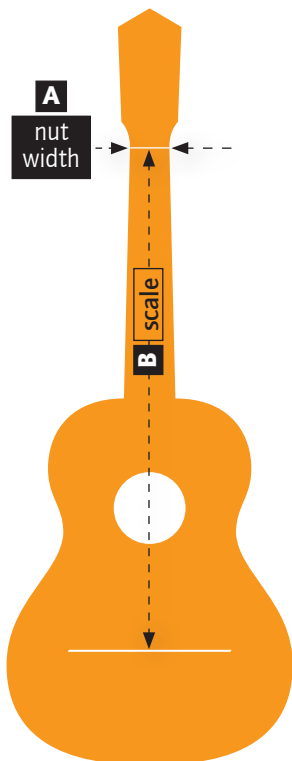

	FULL SIZE
A	52 mm (2.05")
B	650 mm (25.59")
	FULL SIZE MN
	50 mm (1.97")
	650 mm (25.59")
	FULL SIZE SN
	48 mm (1.89")
	650 mm (25.59")
	7/8 SIZE
	47 mm (1.85")
	615 mm (24.21")
	3/4 SIZE
	45 mm (1.77")
	590 mm (23.23")
	1/2 SIZE
	43.5 mm (1.71")
	560 mm (22.05")
	1/4 SIZE
	43.5 mm (1.71")
	438 mm (17.24")

BODY

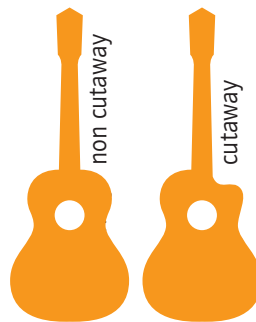

FEATURES



12hole bridge



2way truss rod

ELECTRONICS



ORTEGA
MagusPRO/G

Electronics
(see page 109 -
FULL LINE)

INCL. BAG
(for selected
models)



TRADITIONAL SERIES

MADE IN SPAIN

ortegaguitars.com

5

SPANISH HEEL



scale: 650 mm
nut width: 52 mm

R180L



- Solid North American cedar top, satin finish
- Bubinga back & side, satin finish
- Maple binding
- Mahogany neck, satin finish
- Rosewood fretboard & bridge
- Ortega 12hole bridge
- Handmade in Spain
- Deluxe gig bag included

SPANISH HEEL



scale: 650 mm
nut width: 52 mm

R200L



- Solid North American cedar top, gloss finish
- Palo-rojo back & side, gloss finish
- Maple binding
- Mahogany neck, gloss finish
- Rosewood fretboard & bridge
- Ortega 12hole bridge
- Handmade in Spain
- Deluxe gig bag included

PERFORMER SERIES SOLID SPRUCE TOP/SOLID CEDAR TOP

SLIM NECK/SPANISH HEEL

with EQ **ELECTRONICS W/ TUNER**
ORTEGA
MagusPRO/G

RCE138SN-L with EQ
INCL. BAG
REGULAR BODY DEPTH
FLAT FRETBOARD



RCE138-T4-L with EQ
INCL. BAG
THINLINE BODY DEPTH
RADIUS FRETBOARD



RCE138-T4BK-L with EQ
INCL. BAG
THINLINE BODY DEPTH
RADIUS FRETBOARD



FULL SIZE

scale
650 mm (25.59")

nut width
48 mm (1.89")

- Solid Alaskan Sitka spruce top, gloss finish || gloss black finish
- Sapele back & side, gloss finish || gloss black finish
- Mahogany neck, gloss finish || gloss black finish
- 14th fret heel to body connection (RCE138-T4-L & RCE138-T4BK-L)

- Indian Laurel fretboard & bridge
- Radius fretboard (RCE138-T4-L & RCE138-T4BK-L)
- Ortega MagusPRO electronics w/ tuner
- Ortega 12hole bridge

- Ortega signature walnut/maple/white pearl rosette
- 2way truss rod
- Deluxe gig bag included





PERFORMER SERIES SOLID SPRUCE TOP/SOLID CEDAR TOP

SPANISH HEEL



ELECTRONICS W/ TUNER
ORTEGA
MagusPRO/G



MEDIUM NECK

	scale	nut width
FULL SIZE	650 mm (25.59")	50 mm (1.97")

RCE159MN-L



- Solid North American cedar top, gloss finish
- Walnut back & side, gloss finish
- Mahogany neck, gloss finish
- Indian Laurel fretboard & bridge
- Ortega MagusPRO electronics w/ tuner
- Ortega 12hole bridge
- Ortega signature walnut/maple/white pearl rosette
- 2way truss rod
- Deluxe gig bag included

RCE238SN-FT-L



6 IN LINE
LOCKING
MACHINES
SLIM NECK

	scale	nut width
FULL SIZE	650 mm (25.59")	48 mm (1.89")



- Solid Alaskan Sitka spruce top, gloss burst finish
- Mahogany back & side, gloss finish
- Mahogany neck, gloss finish
- Indian Laurel fretboard & bridge
- Ortega OTMLOCK6L-CR locking machines
- Ortega Magus Pro electronics w/ tuner
- Ortega 12hole bridge
- Ortega signature rosette walnut/maple/white pearl
- 2way truss rod
- Deluxe gig bag included

SIGNATURE SERIES



ELECTRONICS W/ TUNER
ORTEGA
FISHMAN



SOLID TOP
RADIUS
FRETBOARD
SLIM NECK



Thomas Zwijsen
Signature model/custom made



TZSM-3-L



- Solid Canadian Spruce top, gloss finish
- Spalted Maple back and side, satin finish
- Mahogany neck, satin finish
- Maple binding w/ walnut support
- Maple fretboard, 12" Radius
- Ortega 6hole bridge, pao ferro
- Ortega/Fishman Clasica Blend System w/ jack & XLR (D.I.) output w/ tuner
- 2way truss rod
- Thomas Zwijsen Signature soft case included

scale: 650 mm
nut width: 48 mm

FAMILY SERIES PRO SOLID SPRUCE TOP

FULL SIZE



ELECTRONICS W/ TUNER
ORTEGA
 MagusPRO/G



**THINLINE
 BODY DEPTH
 SLIM NECK**

	scale	nut width
FULL SIZE	650 mm (25.59")	48 mm (1.89")

RCE145LBK



- Solid Canadian Engelmann spruce top, gloss black finish
- Mahogany back & side, gloss black finish
- Mahogany neck, gloss black finish
- Walnut fretboard (flat) & bridge
- Ortega MagusPRO electronics w/ tuner
- Ortega 12hole bridge
- 2way truss rod
- Deluxe gig bag included

SOLID CEDAR TOP

FULL SIZE



ELECTRONICS W/ TUNER
ORTEGA
 MagusPRO/G



R131L
 INCL. BAG



RCE131L
 INCL. BAG



R131SN-L
 INCL. BAG
 SLIM NECK



RCE131SN-L
 INCL. BAG
 SLIM NECK

- Solid Canadian Western Red Cedar top, satin finish
- Mahogany back & side, satin finish
- Mahogany neck, satin finish
- Walnut fretboard & bridge
- Ortega MagusPRO electronics w/ tuner (RCE131L & RCE131SN-L)
- Ortega 12hole bridge
- 2way truss rod
- Deluxe gig bag included



	scale	nut width
FULL SIZE SN	650 mm (25.59")	48 mm (1.89")
FULL SIZE	650 mm (25.59")	52 mm (2.05")



FAMILY SERIES SPRUCE TOP



R121-1/4-L
INCL. BAG
1/4 SIZE



R121L-1/2
INCL. BAG
1/2 SIZE



R121L-3/4
INCL. BAG
3/4 SIZE



R121-7/8-L
INCL. BAG
7/8 SIZE



R121SN-L
INCL. BAG / FULL SIZE
SLIM NECK



R121L
INCL. BAG
FULL SIZE

- Spruce top, satin finish
- Mahogany back & side, satin finish
- Mahogany neck, satin finish
- Walnut fretboard & bridge
- Ortega 12hole bridge
- 2way truss rod (1/2, 3/4, 7/8 & full size)
- Deluxe gig bag included



	scale	nut width
1/4 SIZE	438 mm (17.24")	43.5 mm (1.71")
1/2 SIZE	560 mm (22.05")	43.5 mm (1.71")
3/4 SIZE	590 mm (23.23")	45 mm (1.77")
7/8 SIZE	615 mm (24.21")	47 mm (1.85")
FULL SIZE SN	650 mm (25.59")	48 mm (1.89")
FULL SIZE	650 mm (25.59")	52 mm (2.05")



R121LWR
INCL. BAG
FULL SIZE



R221BK-L
INCL. BAG
FULL SIZE



RCE125SN-L
INCL. BAG
FULL SIZE / SLIM NECK / THINLINE BODY



ELECTRONICS W/ TUNER
ORTEGA
MagusPRO/G

FULL SIZE

scale
650 mm (25.59")

nut width
52 mm (2.05")

FULL SIZE SN

scale
650 mm (25.59")

nut width
48 mm (1.89")

- Spruce top, satin finish || gloss wine red finish (WR) || gloss finish black (BK)
- Mahogany back & side, satin finish || gloss wine red finish (WR) || gloss finish black (BK)
- Mahogany neck, satin finish || gloss wine red finish (WR) || gloss finish black (BK)
- Walnut fretboard & bridge
- Mahogany body & fretboard binding (R221BK-L)
- White abalone style purfling (R221BK-L)
- Ortega MagusPRO electronics w/ tuner (RCE125SN-L)
- Ortega 12hole bridge
- 2way truss rod (3/4, 7/8 & full size)
- Deluxe gig bag included





R122-1/4-L
INCL. BAG
1/4 SIZE

R122-1/2-L
INCL. BAG
1/2 SIZE

R122L-3/4
INCL. BAG
3/4 SIZE

R122-7/8-L
INCL. BAG
7/8 SIZE

R122SN-L
INCL. BAG / FULL SIZE
SLIM NECK

R122L
INCL. BAG
FULL SIZE

- Cedar top, satin finish
- Mahogany back & side, satin finish
- Mahogany neck, satin finish
- Walnut fretboard & bridge
- Ortega 12hole bridge
- 2way truss rod (1/2, 3/4, 7/8 & full size)
- Deluxe gig bag included



	scale	nut width
1/4 SIZE	438 mm (17.24")	43.5 mm (1.71")
1/2 SIZE	560 mm (22.05")	43.5 mm (1.71")
3/4 SIZE	590 mm (23.23")	45 mm (1.77")
7/8 SIZE	615 mm (24.21")	47 mm (1.85")
FULL SIZE SN	650 mm (25.59")	48 mm (1.89")
FULL SIZE	650 mm (25.59")	52 mm (2.05")

STUDENT SERIES



RSTC5M-L

	scale	nut width
FULL SIZE	650 mm (25.59")	52 mm (2.05")

- Cedar top, satin finish
- Catalpa back & side, satin finish
- Classical rosette
- ABS binding
- Mahogany neck, satin finish
- Walnut fretboard & bridge
- Ortega 6hole bridge





ORTEGA® OPTIONS

SCALES & SIZES

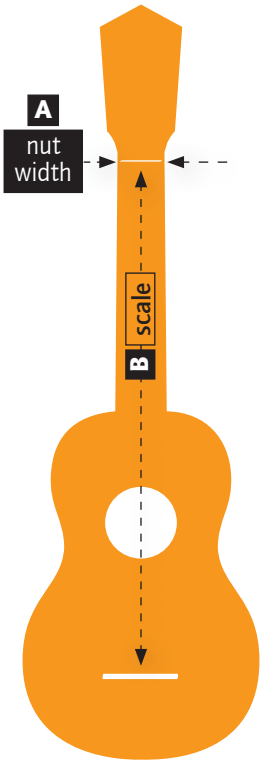

CONCERT	
A	35 mm (1.38")
B	380/376 mm (14.96"/14.80")
	36 mm (1.42")
	380/376 mm (14.96"/14.80")
	38 mm (1.49")
	380/376 mm (14.96"/14.80")
SOBRANO	
	35 mm (1.38")
	350/346/344 mm (13.78"/13.76"/13.54")
	36 mm (1.42")
	350/346/344 mm (13.78"/13.76"/13.54")
BANJOLELE	
	35 mm (1.38")
	394 mm (15.51")
BASS	
	45 mm (1.77")
	510 mm (20.08")

BODY

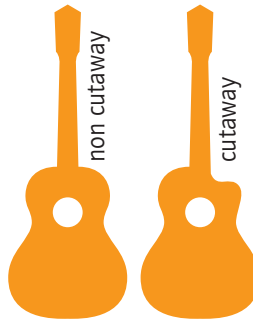

TUNING

CC/SO = G-C-E-A
BS = E-A-D-G

features



Preinstalled strap button on most Ortega ukuleles

INCL. DELUXE GIG BAG
(for selected models)



electronics

ORTEGA® MagusUke

ORTEGA® MagusUkeGO

Electronics w/ tuner (see page 109 - FULL LINE)

BONFIRE SERIES



RU5L



RU5CE-L



RU5MM-L

- Spruce || Mahogany (MM) satin finish, laser engraved motif
- Sapele back & side, satin finish
- Mahogany neck, satin finish
- Tortoise style ABS binding
- Walnut fretboard & bridge
- RU5CE-L: Ortega MagusUkeGO electronics
- Die-cast tuning machines, chrome w/ black buttons

	scale	nut width
CONCERT	380 mm (14.96")	36 mm (1.42")



- Okoume top, back & side, dawn sunburst || ocean blue || coal black, satin finish
- Mahogany neck, satin finish
- White ABS binding
- Walnut fretboard & bridge
- Ortega MagusUkeGO electronics (-CE)
- Die-cast tuning machines, chrome w/black buttons

	scale	nut width
CONCERT	380 mm (14.96")	36 mm (1.42")

DAWN = Dawn Sunburst
OCEAN = Ocean Blue
COAL = Coal Black

HORIZON SERIES



- Mahogany (MM) || Mango (MG) top, satin open pore finish
- Mahogany (MM) || Mango (MG) back & side, satin open pore finish
- Reversed headstock, 4 in line
- Okoume neck & Mahogany headstock veneer || Okoume neck & Mango headstock veneer, satin finish
- Walnut top, bottom & fretboard binding
- Tecwood fretboard & bridge
- Die-cast tuning machines, black (MM) || Die-cast tuning machines, gold w/black buttons (MG)
- Ortega MagusUkeGO electronics (-CE)
- Deluxe gig bag included (RUMGxx)

	scale	nut width
CONCERT	376 mm (14.80")	35 mm (1.38")

MM = Natural Mahogany
MG = Mango





TIMBER SERIES



CONCERT

scale
380 mm (14.96")

nut width
36 mm (1.42")



RFU11Z-L
INCL. BAG

RFU11ZE-L 
INCL. BAG

- Zebra wood top, satin finish
- Zebra wood back & side, satin finish
- Mahogany neck, satin finish
- Walnut fretboard & bridge
- Ortega MagusUkeGO electronics (E)

- Die-cast tuning machines, chrome w/ black buttons
- Deluxe gig bag included



CONCERT

scale: 380 mm (14.96")
nut width: 36 mm (1.42")

RUEB-CC-L

- Ebony top, satin open pore finish
- Ebony back & side, satin open pore finish
- Mahogany neck, satin finish
- Ebony headstock veneer
- Tortoise style binding & tortoise style rosette
- Walnut fretboard & bridge
- Die-cast tuning machines, gold w/ black buttons
- Deluxe gig bag included



SOLID TOP



CONCERT

scale: 382 mm (15.04")
nut width: 36 mm (1.42")

RUTI-CC-L

- SOLID cedar top, satin finish
- Walnut back & side, satin finish
- Okoume neck, satin finish
- Walnut/maple body binding
- Walnut fretboard & bridge
- Maple "bar" fretboard inlays
- Walnut fretboard binding
- Classic headstock, Ovangkol veneer
- Bone nut & saddle
- Die-cast tuning machines, gold w/ black buttons
- Deluxe gig bag included



LIZARD SERIES

with EQ
ELECTRONICS
ORTEGA
MagusUkeGO



CONCERT

scale: 380 mm (14.96")
nut width: 36 mm (1.42")

LIZARD-CC-GBL **with EQ**



- Paldao top, satin finish
- Paldao back & side, satin finish
- Mahogany neck, gloss finish
- Walnut binding
- Walnut fretboard & bridge
- Maple Lizard fretboard inlay
- Ortega MagusUkeGO electronics
- Die-cast tuning machines, gold w/ gold buttons
- Ortega Guitars UWNY-4-CC strings
- Deluxe gig bag included

BANJOLELE SERIES

with E
BUILT-IN PASSIVE
PICKUP SYSTEM
PICKUP
BUILT-IN



scale: 394 mm (15.51")
nut width: 35 mm (1.38")

OUBJE90-MA-L **with E**



- 4string Banjolele
- Hard maple neck, natural, satin finish
- Maple body, open back
- Maple fretboard w/ black ABS binding
- 12 brackets, brushed brass
- Remo head, coated
- Open gear brushed brass tuning machines
- Passive transducer pickup system built-in
- Deluxe bag included

UKEBASSES



LIZARD SERIES

with EQ
ELECTRONICS W/ TUNER
ORTEGA
MagusUke



scale: 510 mm (20.08")
nut width: 45 mm (1.77")

LIZZY-BS-GB-L **with EQ**



- Mahogany top, satin finish
- Mahogany back & side, satin finish
- Mahogany neck, satin finish
- Walnut fretboard & bridge
- Black ABS binding/white purfling
- Ortega MagusUkeBass electronics w/ tuner
- 15 frets
- 2way truss rod
- Deluxe gig bag included

Keiki® UKULELES OPTIONS

ALL K2 & K3 UKULELE PACKS INCLUDES:

- Keiki® K2 or K3 Ukulele
- Keiki® Headstock tuner
- Keiki® Soundhole hook strap/support
- Keiki® 5 medium picks
- Keiki® Drawstring bag

scales & sizes

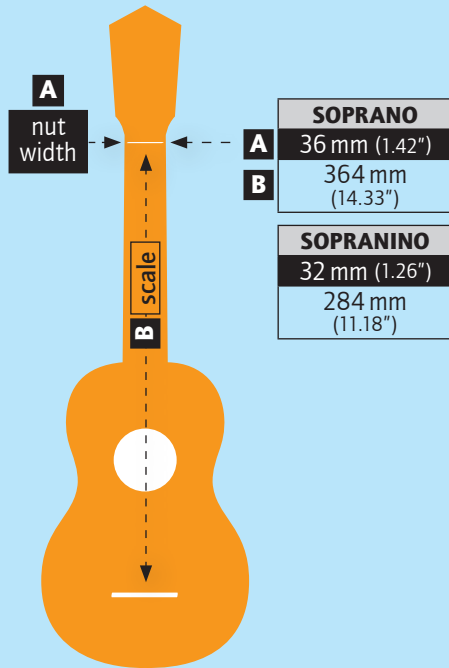

K1 SERIES



K1-BL-L

K1-MM-L

- Laser engraved sea turtle
- Okoume top satin, open pore
- Okoume back & side, satin open pore
- Keiki® headstock design w/ laser logo
- Okoume neck & headstock veneer, satin finish
- Walnut fretboard & bridge
- Open gear tuning machines chrome w/ black buttons
- Available colors:
BL - ocean blue
MM - natural mahogany

	scale	nut width
SOPRANINO	284 mm (11.18")	32 mm (1.26")



K2 SERIES UKULELE PACK



**K2-68-L
PACK**

	scale	nut width
SOPRANO	364 mm (14.33")	36 mm (1.42")

- Agathis top, custom designed
- ABS body, slightly arched
- Keiki® headstock design w/ custom designed veneer
- Okoume neck, satin finish
- ABS fretboard & bridge
- Open gear tuning machines chrome w/ black buttons
- Headstock tuner, soundhole hook strap/support, 5 medium picks and drawstring bag included!



K2 SERIES UKULELE PACK



**UKULELE
PACK**

SOPRANO

scale
364 mm (14.33")

nut width
36 mm (1.42")



**K2-MAH-L
PACK**



**K2-MAP-L
PACK**

- Mahogany (MAH) || Maple (MAP) top, satin finish
- ABS body, slightly arched
- Okoume neck, satin finish
- ABS fretboard & bridge
- Open gear tuning machines chrome w/ black buttons
- Headstock tuner, soundhole hook strap/support, 5 medium picks and drawstring bag included!
- Available designs:
K2-MAH-L - Mahogany
K2-MAP-L - Maple

K3 SERIES UKULELE PACK



**K3-SPM-L
PACK**

	scale	nut width
SOPRANO	364 mm (14.33")	36 mm (1.42")

- Spalted Maple top, satin finish
- ABS body, slightly arched
- Okoume neck, satin finish
- ABS fretboard & bridge
- Open gear tuning machines chrome w/ black buttons
- Headstock tuner, soundhole hook strap/support, 5 medium picks and drawstring bag included!





DEEP SERIES

D538-4-L



SOLID SPRUCE

- Solid Alaskan spruce top, satin finish
- Sapele back & side, open pore finish
- Mahogany neck, open pore finish
- Pao Ferro fretboard w/ black ABS binding
- Pao Ferro bridge
- Black ABS binding/bk-wh-bk purfling
- Chrome hardware
- ORTEGA MagusPRO/B electronics w/ tuner
- 2way truss rod



ELECTRONICS W/ TUNER
ORTEGA
MagusPRO/B

medium scale: 812 mm (32")
nut width: 45 mm (1.77")
body depth: 122 mm (4.80")

THE PRIVATE ROOM

STRIPSU.ACB-L



BUILT-IN ARMREST
AAA STRIPED EBONY
BACK & SIDE



- Solid Alaskan spruce top, gloss finish
- AAA striped ebony back & side, gloss finish
- Acacia top & bottom binding /white purfling
- Mahogany neck, gloss finish
- Medium scale
- Tecwood fretboard w/ walnut binding
- Tecwood bridge
- 2way truss rod
- Ortega signature walnut/maple/white pearl rosette
- Ortega die-cast tuning machines, gold
- Ortega MagusPRO electronics w/ tuner
- Deluxe gig bag included



ELECTRONICS W/ TUNER
ORTEGA
MagusPRO/B

medium scale: 812 mm (32")
nut width: 45 mm (1.77")
body depth: 122 mm (4.80")

MANDOLINS

RMA5NA-L



scale: 345 mm (13.58")
nut width: 28 mm (1.10")

NA (natural)

- Mahogany top, open pore satin finish
- Mahogany back (arched) & side, open pore satin finish
- Mahogany neck, satin finish
- Ovangkol fretboard & bridge
- 2way truss rod
- 20 frets



BUILT-IN PASSIVE
PICKUP SYSTEM
PICKUP
BUILT-IN



scale: 345 mm (13.58")
nut width: 28 mm (1.10")

SBK (satin black)

RMAE4OSBK-L



- Spruce top, satin black finish
- Maple back (arched) & side, satin black finish
- Maple neck, satin black finish
- Rosewood fretboard & bridge
- 2way truss rod
- 20 frets
- Piezo bridge with tone & volume control, passive
- Deluxe gig bag included

BANJOS

BUILT-IN PASSIVE PICKUP SYSTEM
with **E**
PICKUP BUILT-IN



6STRING GUITAR BANJO

OBJE356-SBK-L

with **E**

- Mahogany neck & resonator, satin black finish
- Ovangkol fretboard
- Aluminum rim
- Chrome armrest, Ortega engraved
- 30 brackets, chrome hardware
- Remo ebony head, black
- Die-cast machine head
- Built-in passive pickup system w/ volume control
- Deluxe gig bag included



BUILT-IN PASSIVE PICKUP SYSTEM
with **E**
PICKUP BUILT-IN

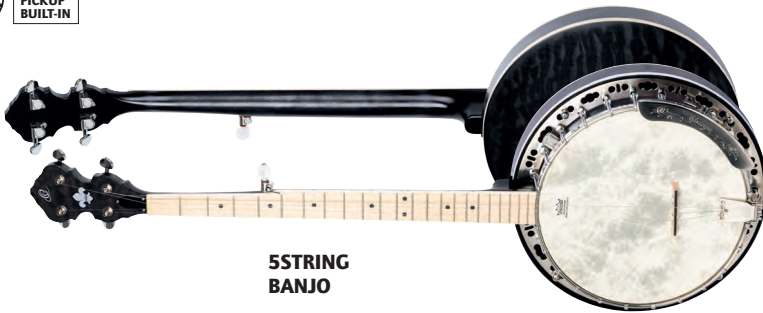

5STRING BANJO

OBJE400TCO-L

with **E**

- Quilted maple resonator, semi-gloss coal black finish
- Maple ply rim, coal black, semi-gloss finish
- Hard maple neck, Maple fingerboard
- Brass tone ring, 24 brackets
- Brushed nickel hardware
- Die-cast machine head
- Remo head, fiberskin style
- Deluxe gig bag included



ACCESSORIES

SOFT CASES



SPECIAL LEFT-HANDED GIG BAG

NEW

Travel in style with hard-case like protection with significantly less weight! Ortega premium **SOFT CASES** are made with a canvas/cotton surface and real suede leather inlays. The 22 mm (0.86") soft sponge padding is supported by a 5 mm (0.20") hardened PE plastic frame. A plush black velvet material interior includes a neck brace with Velcro safety straps. The exterior features heavy duty zippers, comfortable, adjustable shoulder straps, and a suede leather covered handle.

Available color: CP = CAPPUCCINO

DIMENSIONS

ACOUSTIC DREADNOUGHT	A	B	C	D	Height
OSOCADN-CP-L dreadnought	107.0 cm 42.13"	14.0 cm 5.51"	33.0 cm 12.99"	42.0 cm 16.54"	13.0 cm 5.12"
CLASSICAL	A	B	C	D	Height
OSOCACL-CP-L regular classic size	103.5 cm 40.75"	12.0 cm 4.72"	31.0 cm 12.2"	39.0 cm 15.35"	11.5 cm 4.53"

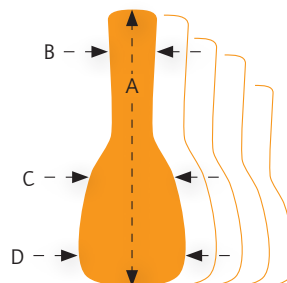

2022 LEFT HANDED

#OrtegaLovesLefties

ORTEGA[®]
GUITARS • EST 1994



FULL LINE
PLEASE TURN OVER

